

cilindri corsa breve

short stroke cylinders

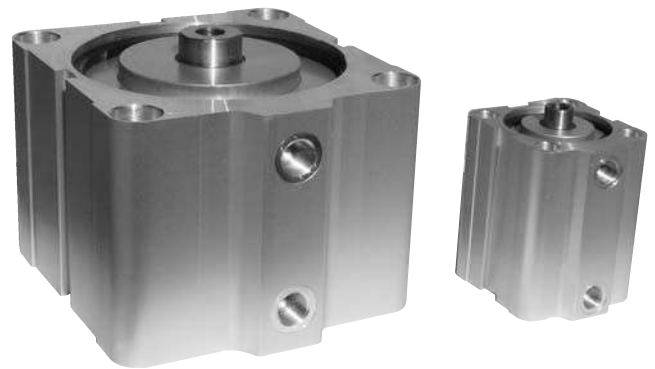

- Dimensioni di ingombro ridotte
Reduced external dimensions
- Grande affidabilità e lunga durata
High reliability and long life time
- Versione magnetica standard
Standard magnetic version
- Esecuzioni e corse speciali a richiesta
Special versions and strokes on request



Materiali

Camicia: alluminio

Stelo: C45 cromato o INOX AISI 304

Testate: alluminio con boccia guida stelo

Pistone: ottone fino all'alesaggio 25; tecnopolimero dall'alesaggio 32 al 100 (alluminio su richiesta). Il pistone in tecnopolimero non è adatto per la versione ATEX.

Guarnizioni: poliuretano o VITON

Guarnizione stelo: poliuretano o VITON

Magnete: neodimio fino all'alesaggio 25

plastoferrite dall'alesaggio 32 al 100

Il magnete non è adatto per temperature oltre +60°C

Materials

Barrel: aluminium

Piston-rod: C45 (chromium plated) or stainless steel

End-cups: aluminium with rod guide

Piston: brass from bore 16 to 25; technopolymer from bore 32 to 100 (aluminium on request). The piston in technopolymer is not suitable for ATEX.

Sealings: polyurethane or VITON

Piston-rod sealing: polyurethane or VITON

Magnet: neodymium from bore 16 to 25

magnetic iron compound from bore 32 to 100

The magnet is not suitable for temperatures over +60°C

Pressione di esercizio <i>Working pressure</i>	max 10 bar max 1 MPa
Temperatura di esercizio <i>Temperature range</i>	standard (poliuretano/NBR): max +60°C VITON: max +110°C
Alesaggi <i>Bores</i>	16; 20; 25; 32; 40; 50; 63; 80; 100 mm
Corse <i>Strokes</i>	5 ... 100 mm
Fluido <i>Fluid</i>	Aria filtrata 50µ con o senza lubrificazione 50µ filtered, lubricated or non lubricated air

chiave di codifica

key to codes

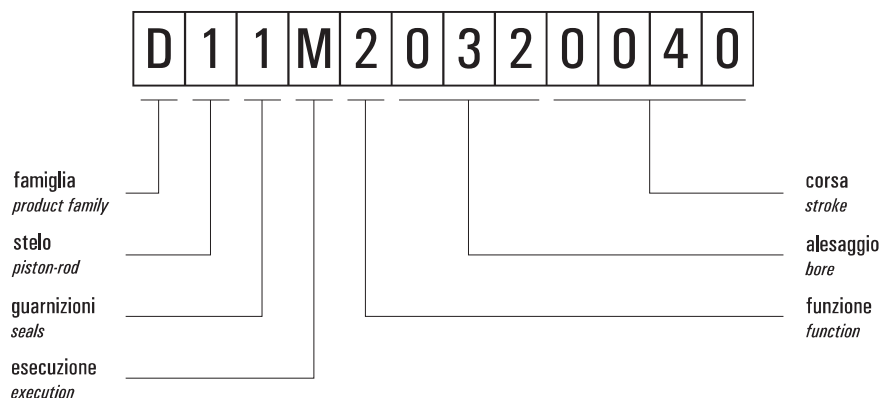

Famiglia *[product family]*

D cilindri corsa breve *[short stroke cylinders]*

Stelo *[piston-rod]*

1 C45 cromato *[C45 chromium plated]*

2 INOX *[stainless steel]*

Guarnizioni *[seals]*

1 poliuretano

2 tutte le guarnizioni in VITON

[all seals in VITON]

3 guarnizioni dello stelo in VITON *[rod seals in VITON]*

Esecuzione *[execution]*

M magnetico *[magnetic]*

Funzione *[function]*

1 semplice effetto non ammortizzato molla anteriore
[single acting front spring without pneumatic cushioning]

2 doppio effetto non ammortizzato
[double acting without pneumatic cushioning]

3 semplice effetto non ammortizzato molla posteriore
[single acting back spring without pneumatic cushioning]

4 doppio effetto non ammortizzato stelo passante
[double acting without pneumatic cushioning, with passing-through rod]

6

cilindri corsa breve

short stroke cylinders



disegno valido dall'alesaggio 32 all'alesaggio 100
the drawing is valid from bore 32 to bore 100

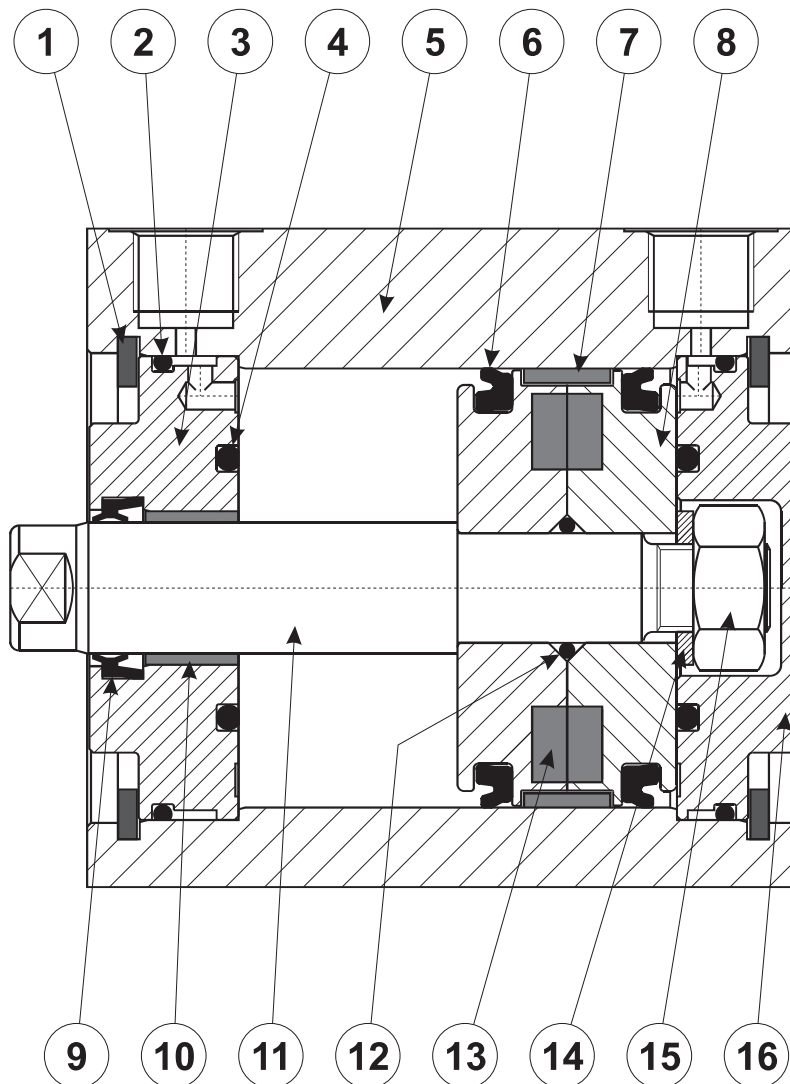

1. Anello SEEGER per fissaggio testata
2. O-Ring per tenuta testata: NBR o VITON
3. Testata anteriore: alluminio
4. O-Ring paracolpi: NBR o VITON
5. Camicia: alluminio profilato, calibrato e anodizzato
6. Guarnizione a labbro per pistone: poliuretano o VITON
7. Anello guida per pistone: bronzo PTFE (solo per pistone in alluminio)
8. Pistone: tecnopolimero o alluminio
9. Guarnizione stelo: poliuretano o VITON
10. Boccole guida: materiale autolubrificante
11. Stelo: acciaio C45 cromato o INOX AISI 304
12. O-Ring per tenuta pistone: NBR o VITON
13. Magnete: plastoferrite
14. Rondella piana
15. Dado per bloccaggio stelo
16. Testata posteriore: alluminio

cilindri corsa breve

short stroke cylinders



versioni disponibili

available versions

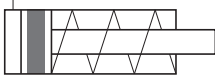
semplice effetto molla anteriore <i>single acting front spring</i> magnetico <i>magnetic</i> non ammortizzato <i>without pneumatic cushioning</i>	alesaggio										
	corsa	bore	16	20	25	32	40	50	63	80	100
	5		X	X	X	X	X	X	X	X	X
	10		X	X	X	X	X	X	X	X	X
	25		X	X	X	X	X	X	X	X	X
	30							X	X	X	X
	40										
	50										
	75										
	100										
semplice eff. molla posteriore <i>single acting back spring</i> magnetico <i>magnetic</i> non ammortizzato <i>without pneumatic cushioning</i>	alesaggio										
	corsa	bore	16	20	25	32	40	50	63	80	100
	5		X	X	X	X	X	X	X	X	X
	10		X	X	X	X	X	X	X	X	X
	25		X	X	X	X	X	X	X	X	X
	30							X	X	X	X
	40										
	50										
75											
100											

OPZIONI <i>options</i>		
Lo standard è evidenziato in grigio The standard is marked with grey background		
materiale stelo (piston-rod material)		
C45 cromato <i>C45 chromium plated</i>	INOX <i>stainless steel</i>	
materiale guarnizioni (seals material)		
poliuret.	tutte in VITON <i>all seals in VITON</i>	guarnizioni stelo in VITON <i>rod seals in VITON</i>

OPZIONI <i>options</i>		
Lo standard è evidenziato in grigio The standard is marked with grey background		
materiale stelo (piston-rod material)		
C45 cromato <i>C45 chromium plated</i>	INOX <i>stainless steel</i>	
materiale guarnizioni (seals material)		
poliuret.	tutte in VITON <i>all seals in VITON</i>	guarnizioni stelo in VITON <i>rod seals in VITON</i>

6

cilindri corsa breve

short stroke cylinders



versioni disponibili

available versions

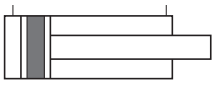
doppio effetto <i>double acting</i> magnetico <i>magnetic</i> non ammortizzato <i>without pneumatic cushioning</i>	alesaggio										
	corsa	bore	16	20	25	32	40	50	63	80	100
	5		X	X	X	X	X	X	X	X	X
	10		X	X	X	X	X	X	X	X	X
	25		X	X	X	X	X	X	X	X	X
	30		X	X	X	X	X	X	X	X	X
	40		X	X	X	X	X	X	X	X	X
	50			X	X	X	X	X	X	X	X
	75								X	X	X
	100									X	X
doppio effetto <i>double acting</i> magnetico <i>magnetic</i> non ammortizzato <i>without pneumatic cushioning</i> stelo passante <i>passing-through rod</i>	alesaggio										
	corsa	bore	16	20	25	32	40	50	63	80	100
	5		X	X	X	X	X	X	X	X	X
	10		X	X	X	X	X	X	X	X	X
	25		X	X	X	X	X	X	X	X	X
	30		X	X	X	X	X	X	X	X	X
	40		X	X	X	X	X	X	X	X	X
	50			X	X	X	X	X	X	X	X
75								X	X	X	
100									X	X	
		OPZIONI <i>options</i> Lo standard è evidenziato in grigio <i>The standard is marked with grey background</i>									
		materiale stelo <i>(piston-rod material)</i>									
		C45 cromato <i>C45 chromium plated</i>					INOX <i>stainless steel</i>				
		materiale guarnizioni <i>(seals material)</i>									
		poliuret.		tutte in VITON <i>all seals in VITON</i>					guarnizioni stelo in VITON <i>rod seals in VITON</i>		

6

cilindri corsa breve

short stroke cylinders



VERSIONE NORMALE

Normal version

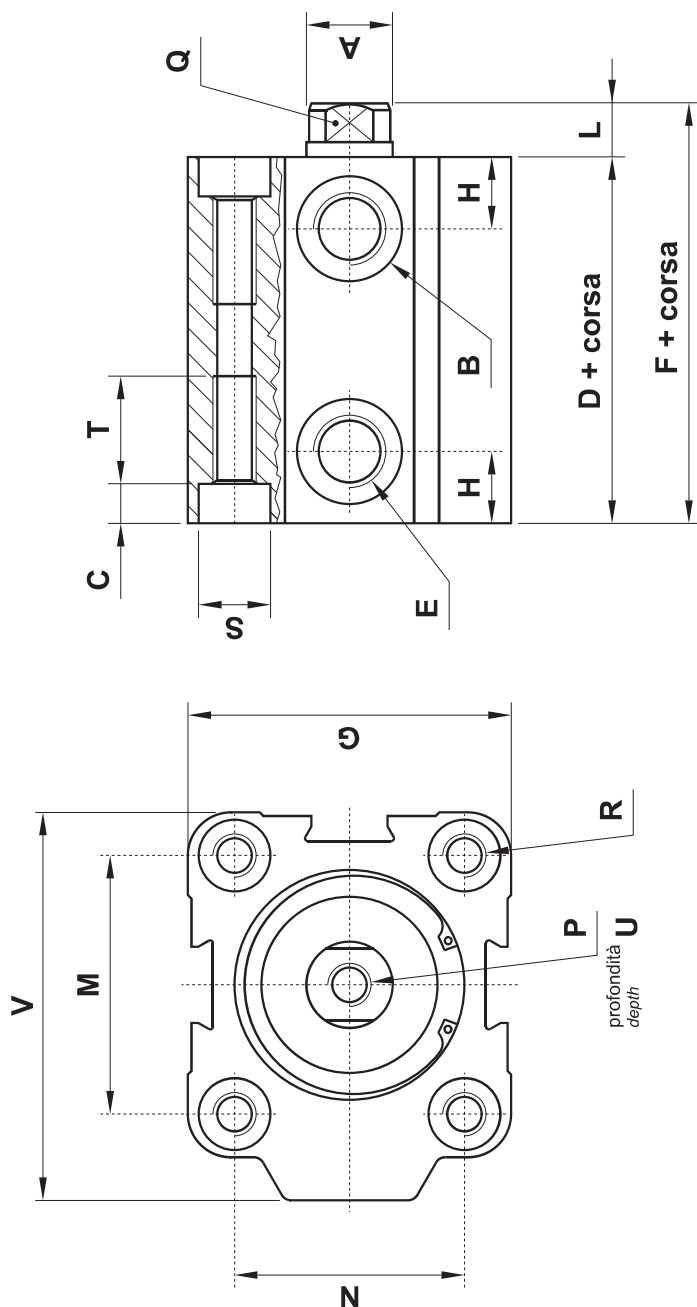

Ø	A	B	C	D	E	F	G	H	L	M	N	P	Q	R	S	T	U	V
16	Ø8	-	3.5	36	M5	41.5	28	8	5.5	20	20	M5	CH 7	M4	Ø6	10	10	31
20	Ø10	-	4.5	36	M5	41.5	32	8.5	5.5	22	22	M5	CH 8	M5	Ø7	12	10	35
25	Ø10	Ø14	4.5	38	G1/8"	43.5	38	9	5.5	28	26	M5	CH 8	M5	Ø7	12	10	44.5
32	Ø12	Ø14	5.5	46.2	G1/8"	53.2	45	9	7	36	32	M8	CH 10	M6	Ø9	17	13.5	54
40	Ø12	Ø14	5.5	46.2	G1/8"	53.2	54.5	10	7	40	40	M8	CH 10	M6	Ø9	17	13.5	60
50	Ø16	Ø14	6.5	50	G1/8"	58	65	11.5	8	50	50	M10	CH 13	M8	Ø11	20	16	72.5
63	Ø16	Ø14	8.5	53	G1/8"	61	80	11.5	8	62	62	M10	CH 13	M10	Ø14	20	16	88
80	Ø20	Ø19	8.5	56.4	G1/4"	66.2	100	13.8	9.8	82	82	M10	CH 17	M10	Ø14	22.5	20	110
100	Ø25	Ø19	11	67	G1/4"	77	124	17	10	103	103	M12	CH 22	M12	Ø17	24	24	134

cilindri corsa breve

short stroke cylinders



VERSIONE SEMPLICE EFFETTO MOLLA ANTERIORE

Single acting version, front spring

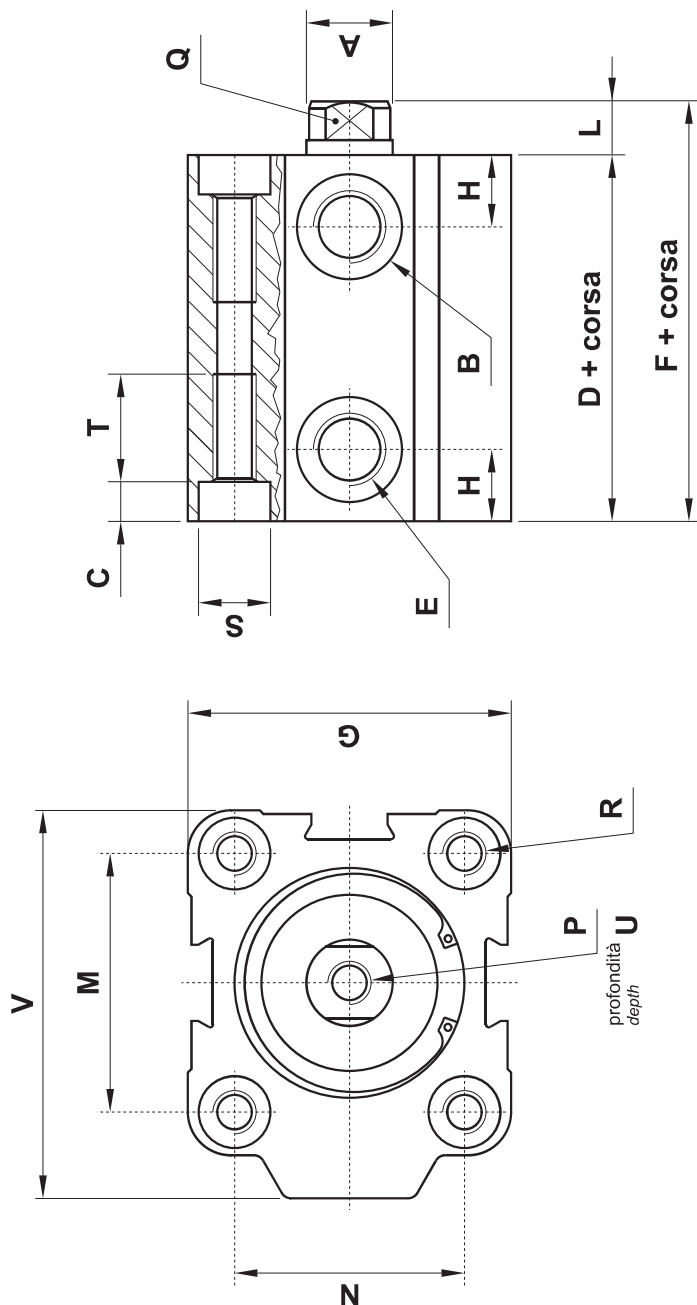

Ø	A	B	C	D	E	F	G	H	I	J	K	L	M	N	O	P	Q	R	S	T	U	V
16	Ø8	-	3.5	51	M5	56.5	28	8	5.5	20	M5	CH 7	M4	Ø6	10	10	10	10	10	10	10	31
20	Ø10	-	4.5	51	M5	56.5	32	8.5	5.5	22	M5	CH 8	M5	Ø7	12	10	10	10	12	10	10	35
25	Ø10	Ø14	4.5	53	G1/8"	58.5	38	9	5.5	26	M5	CH 8	M5	Ø7	12	10	10	10	12	10	10	44.5
32	Ø12	Ø14	5.5	46.2	G1/8"	53.2	45	9	7	32	M8	CH 10	M6	Ø9	17	13.5	10	10	17	13.5	10	54
40	Ø12	Ø14	5.5	46.2	G1/8"	53.2	54.5	10	7	40	M8	CH 10	M6	Ø9	17	13.5	10	10	17	13.5	10	60
50	Ø16	Ø14	6.5	50	G1/8"	58	65	11.5	8	50	M10	CH 13	M8	Ø11	20	16	10	10	20	16	10	72.5
63	Ø16	Ø14	8.5	53	G1/8"	61	80	11.5	8	62	M10	CH 13	M10	Ø14	20	16	10	10	20	16	10	88
80	Ø20	Ø19	8.5	56.4	G1/4"	66.2	100	13.8	9.8	82	M10	CH 17	M10	Ø14	22.5	20	10	10	22.5	20	10	110
100	Ø25	Ø19	11	67	G1/4"	77	124	17	10	103	M12	CH 22	M12	Ø17	24	24	10	10	24	24	10	134

cilindri corsa breve

short stroke cylinders



VERSIONE SEMPLICE EFFETTO MOLLA POSTERIORE

Single acting version, back spring

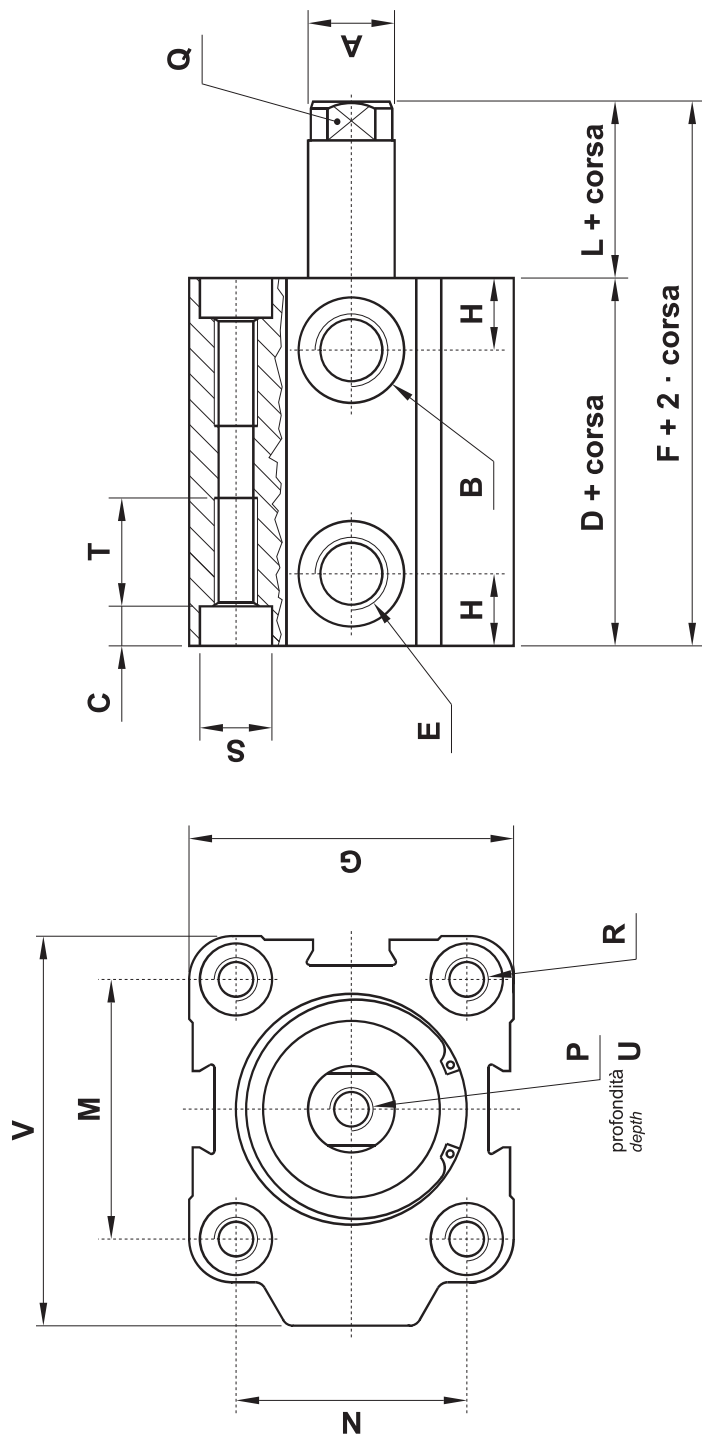

Ø	A	B	C	D	E	F	G	H	I	J	K	L	M	N	O	P	Q	R	S	T	U	V
16	Ø8	-	3.5	51	M5	56.5	28	8	5.5	20	M5	CH 7	M4	Ø6	10	10	10	10	10	10	10	31
20	Ø10	-	4.5	51	M5	56.5	32	8.5	5.5	22	M5	CH 8	M5	Ø7	12	10	10	10	12	10	10	35
25	Ø10	Ø14	4.5	53	G1/8"	58.5	38	9	5.5	26	M5	CH 8	M5	Ø7	12	10	10	10	12	10	10	44.5
32	Ø12	Ø14	5.5	46.2	G1/8"	53.2	45	9	7	32	M8	CH 10	M6	Ø9	17	13.5	10	10	17	13.5	10	54
40	Ø12	Ø14	5.5	46.2	G1/8"	53.2	54.5	10	7	40	M8	CH 10	M6	Ø9	17	13.5	10	10	17	13.5	10	60
50	Ø16	Ø14	6.5	50	G1/8"	58	65	11.5	8	50	M10	CH 13	M8	Ø11	20	16	10	10	20	16	10	72.5
63	Ø16	Ø14	8.5	53	G1/8"	61	80	11.5	8	62	M10	CH 13	M10	Ø14	20	16	10	10	20	16	10	88
80	Ø20	Ø19	8.5	56.4	G1/4"	66.2	100	13.8	9.8	82	M10	CH 17	M10	Ø14	22.5	20	10	10	22.5	20	10	110
100	Ø25	Ø19	11	67	G1/4"	77	124	17	10	103	M12	CH 22	M12	Ø17	24	24	10	10	24	24	10	134

cilindri corsa breve

short stroke cylinders



VERSIONE CON STELO PASSANTE

Version with passing-through rod

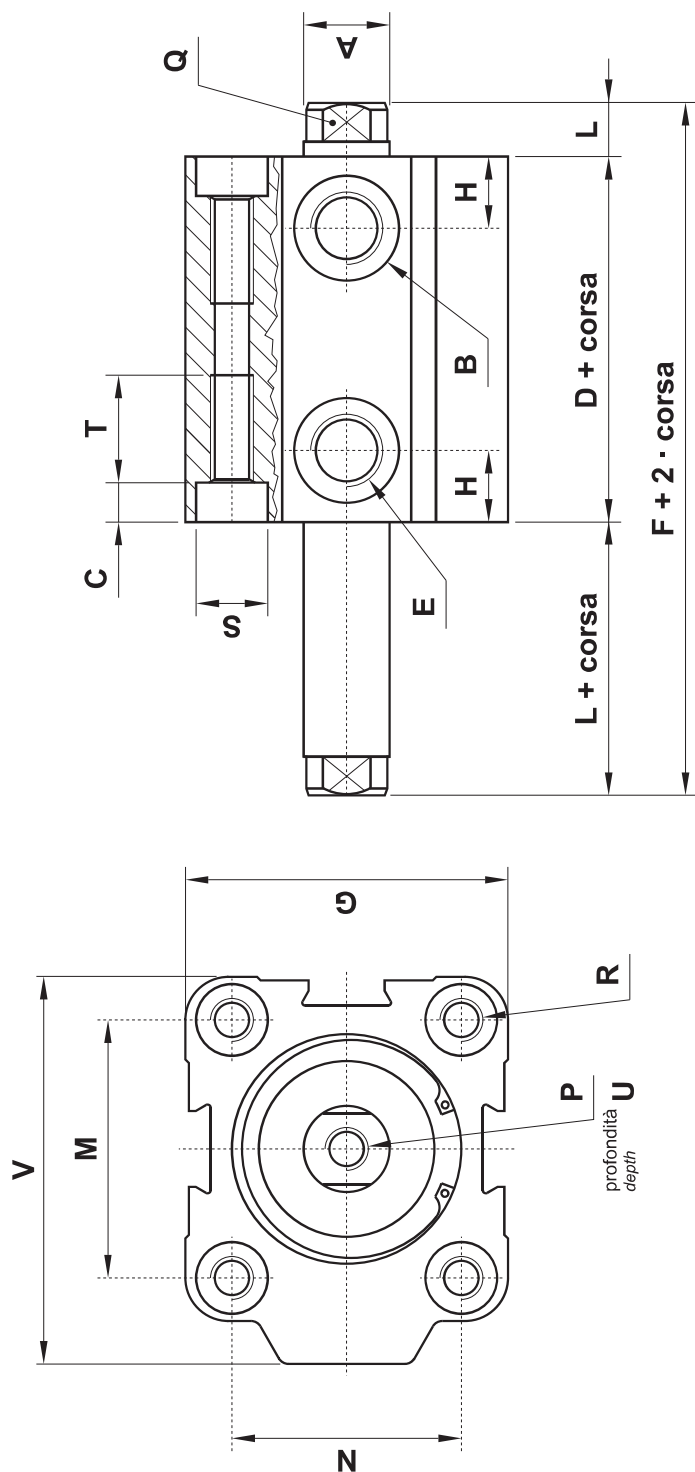

Ø	A	B	C	D	E	F	G	H	L	M	N	P	Q	R	S	T	U	V
16	Ø8	-	3.5	36	M5	47	28	8	5.5	20	20	M5	CH 7	M4	Ø6	10	10	31
20	Ø10	-	4.5	36	M5	47	32	8.5	5.5	22	22	M5	CH 8	M5	Ø7	12	10	35
25	Ø10	Ø14	4.5	38	G1/8"	49	38	9	5.5	28	26	M5	CH 8	M5	Ø7	12	10	44.5
32	Ø12	Ø14	5.5	46.2	G1/8"	60.2	45	9	7	36	32	M8	CH 10	M6	Ø9	17	13.5	54
40	Ø12	Ø14	5.5	46.2	G1/8"	60.2	54.5	10	7	40	40	M8	CH 10	M6	Ø9	17	13.5	60
50	Ø16	Ø14	6.5	50	G1/8"	66	65	11.5	8	50	50	M10	CH 13	M8	Ø11	20	16	72.5
63	Ø16	Ø14	8.5	53	G1/8"	69	80	11.5	8	62	62	M10	CH 13	M10	Ø14	20	16	88
80	Ø20	Ø19	8.5	56.4	G1/4"	76	100	13.8	9.8	82	82	M10	CH 17	M10	Ø14	22.5	20	110
100	Ø25	Ø19	11	67	G1/4"	87	124	17	10	103	103	M12	CH 22	M12	Ø17	24	24	134



kit guarnizioni di ricambio

seals kit

MAGNETICO, guarnizioni standard					
normale			stelo passante [passing-through rod]		
per alesaggio for bore	sigla part number	codice code	per alesaggio for bore	sigla part number	codice code
16	GD016	22.100.2	16	GD016P	22.110.2
20	GD020	22.101.2	20	GD020P	22.111.2
25	GD025	22.102.2	25	GD025P	22.112.2
32	GD032	22.103.2	32	GD032P	22.113.2
40	GD040	22.104.2	40	GD040P	22.114.2
50	GD050	22.105.2	50	GD050P	22.115.2
63	GD063	22.106.2	63	GD063P	22.116.2
80	GD080	22.107.2	80	GD080P	22.117.2
100	GD100	22.108.2	100	GD100P	22.118.2
MAGNETICO, guarnizioni VITON					
normale			stelo passante [passing-through rod]		
per alesaggio for bore	sigla part number	codice code	per alesaggio for bore	sigla part number	codice code
16	GD016V	22.120.2	16	GD016PV	22.130.2
20	GD020V	22.121.2	20	GD020PV	22.131.2
25	GD025V	22.122.2	25	GD025PV	22.132.2
32	GD032V	22.123.2	32	GD032PV	22.133.2
40	GD040V	22.124.2	40	GD040PV	22.134.2
50	GD050V	22.125.2	50	GD050PV	22.135.2
63	GD063V	22.126.2	63	GD063PV	22.136.2
80	GD080V	22.127.2	80	GD080PV	22.137.2
100	GD100V	22.128.2	100	GD100PV	22.138.2

6

dadi per fissaggio in cava

fixing nuts



sigla part number	codice order code	A
DCCB 16/32	26.156.0T	M5
DCCB 32/100	26.157.0T	M6

Permette di fissare un cilindro corsa breve a parete.
It can be used to fix a short stroke cylinder on the side.

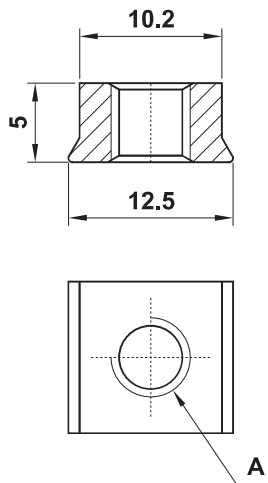

26.374.0T

Permette di fissare un cilindro ISO 15552 serie N a parete.
Si utilizza anche per fissare su un cilindro ISO 15552 serie N le interfacce per valvole, di cui alle pagine 229 e 954.
It can be used to fix a cylinder ISO 15552 series N on the side, and to mount on a cylinder ISO 15552 series N an interface for valves (refer to page 229 and 954).

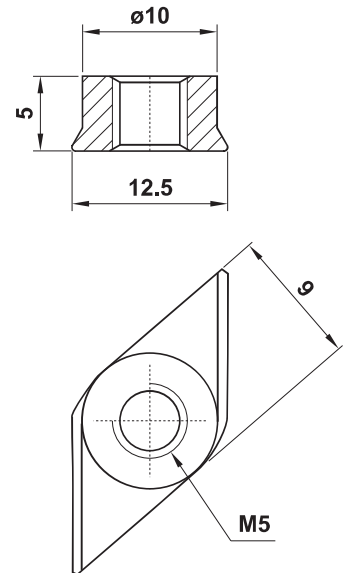

26.375.0T

Permette di fissare un cilindro ISO 15552 serie N a parete.
It can be used to fix a cylinder ISO 15552 series N on the side.

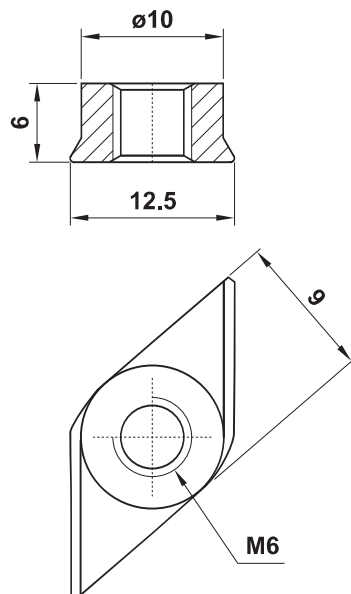

26.376.0T

Si utilizza per fissare su un cilindro ISO 15552 serie E le interfacce per valvole, di cui alla pagina 230.
It can be used to mount on a cylinder ISO 15552 series E an interface for valves (refer to page 230).

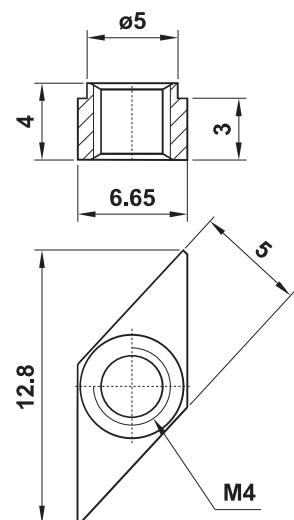

cilindri corsa breve

short stroke cylinders



versione antirotazione

version anti-rotation

D 1 1 L 2 0 3 2 0 0 4 0

famiglia
product family

stelo
piston-rod

guarnizioni
seals

esecuzione
execution

corsa
stroke

alesaggio
bore

funzione
function



Famiglia [product family]

D cilindri corsa breve [short stroke cylinders]

Esecuzione [execution]

L magnetico antirotazione [magnetic anti-rotation]

Stelo [piston-rod]

1 C45 cromato [C45 chromium plated]

Funzione [function]

2 doppio effetto non ammortizzato
[double acting without pneumatic cushioning]

Guarnizioni [seals]

1 poliuretano

2 tutte le guarnizioni in VITON
[all seals in VITON]

3 guarnizioni dello stelo in VITON [rod seals in VITON]

Materiali

Camicia: alluminio

Stelo: C45 cromato

Testate: alluminio con boccola guida stelo

Pistone: ottone fino all'alesaggio 25; tecnopolimero dall'alesaggio 32 al 100 (alluminio su richiesta).

Guarnizioni: poliuretano o VITON

Guarnizione stelo: poliuretano o VITON

Magnete: neodimio fino all'alesaggio 25

plastroferrite dall'alesaggio 32 al 100

Il magnete non è adatto per temperature oltre +60°C

Materials

Barrel: aluminium

Piston-rod: C45 (chromium plated)

End-cups: aluminium with rod guide

Piston: brass from bore 16 to 25; technopolymer from bore 32 to 100 (aluminium on request).

Sealings: polyurethane or VITON

Piston-rod sealing: polyurethane or VITON

Magnet: neodymium from bore 16 to 25

magnetic iron compound from bore 32 to 100

The magnet is not suitable for temperatures over +60°C

Pressione di esercizio <i>Working pressure</i>	max 10 bar max 1 MPa
Temperatura di esercizio <i>Temperature range</i>	standard (poliuretano/NBR): max +60°C VITON: max +110°C
Alesaggi <i>Bores</i>	16; 20; 25; 32; 40; 50; 63; 80; 100 mm
Corse <i>Strokes</i>	5 ... 80 mm
Fluido <i>Fluid</i>	Aria filtrata 50µ con o senza lubrificazione 50µ filtered, lubricated or non lubricated air

cilindri corsa breve

short stroke cylinders



VERSIONE ANTIROTAZIONE - alesaggio 16, 20, 25, 32, 40, 50, 63, 80, 100

Version anti-rotation - bore 16, 20, 25, 32, 40, 50, 63, 80, 100

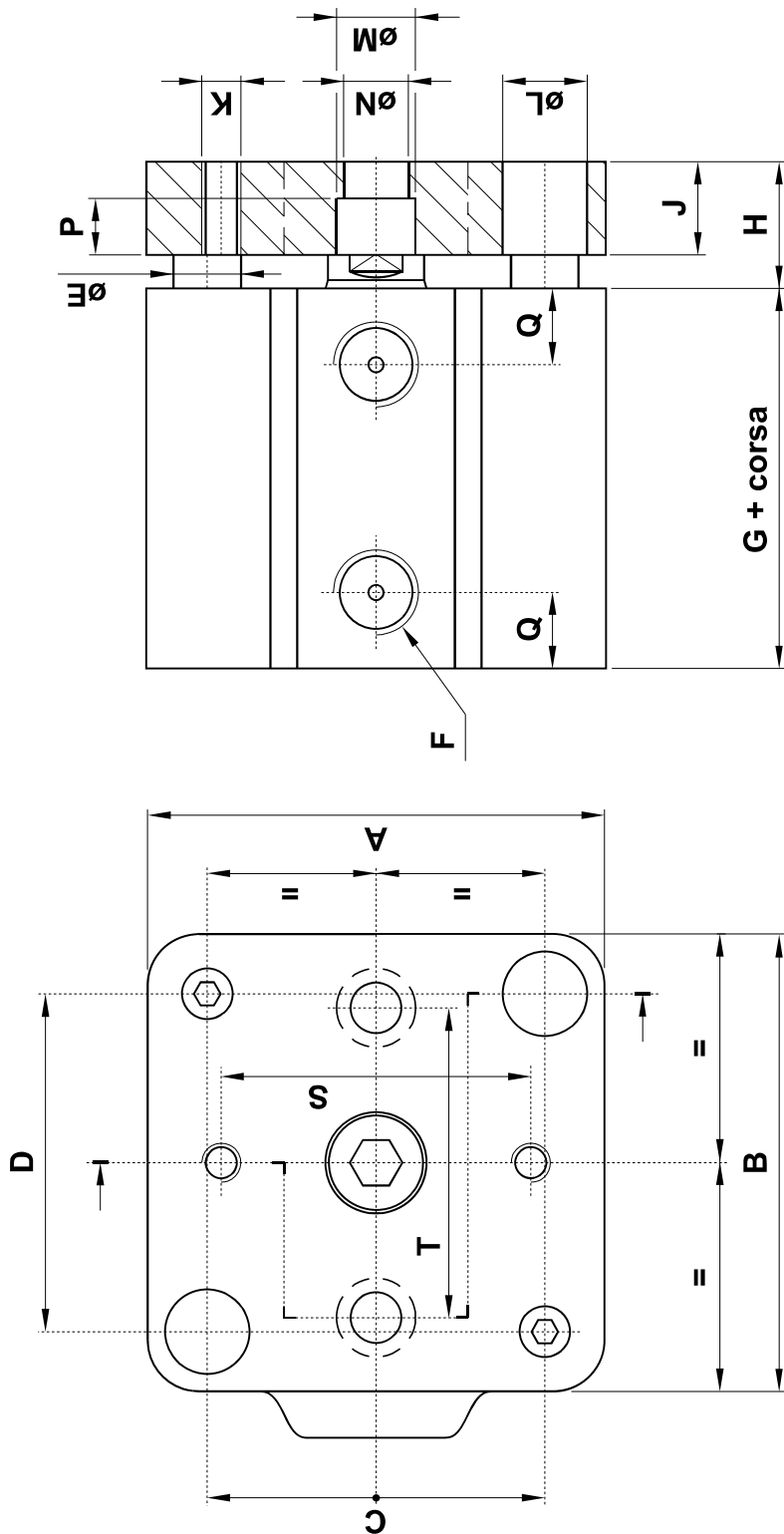

Ø	A	B	C	D	E	F	G	H	J	K	L	M	N	P	Q	S	T
16	28	28	20	20	6	M5	36	13.5	11	M3	6.5	6.5	3.5	3.5	8	15	20
20	32	32	22	22	6	M5	36	13.5	11	M4	8	8	4.8	5	8.5	18	22
25	38	38	26	28	6	G1/8"	38	13.5	11	M4	8	8	4.8	5	9	22	22
32	45	48	32	36	8	G1/8"	46.2	17	13	M5	10	10	5.5	6	9	26	36
40	54	54	40	40	8	G1/8"	46.2	17	13	M5	10	10	5.5	6	10	34	34
50	64.6	64.6	50	50	10	G1/8"	50	20	15	M6	11	11	6.5	6.5	11.5	43	43
63	79.6	79.6	62	62	10	G1/8"	53	20.5	15.5	M6	15	14	9	8.5	11.5	55	55
80	99	99	82	82	12	G1/4"	56.4	23.8	16.5	M8	15	14	9	9	13.8	70	70
100	119.6	119.6	103	103	12	G1/4"	67	26	20	M8	.	14	9	9	17	94	94