

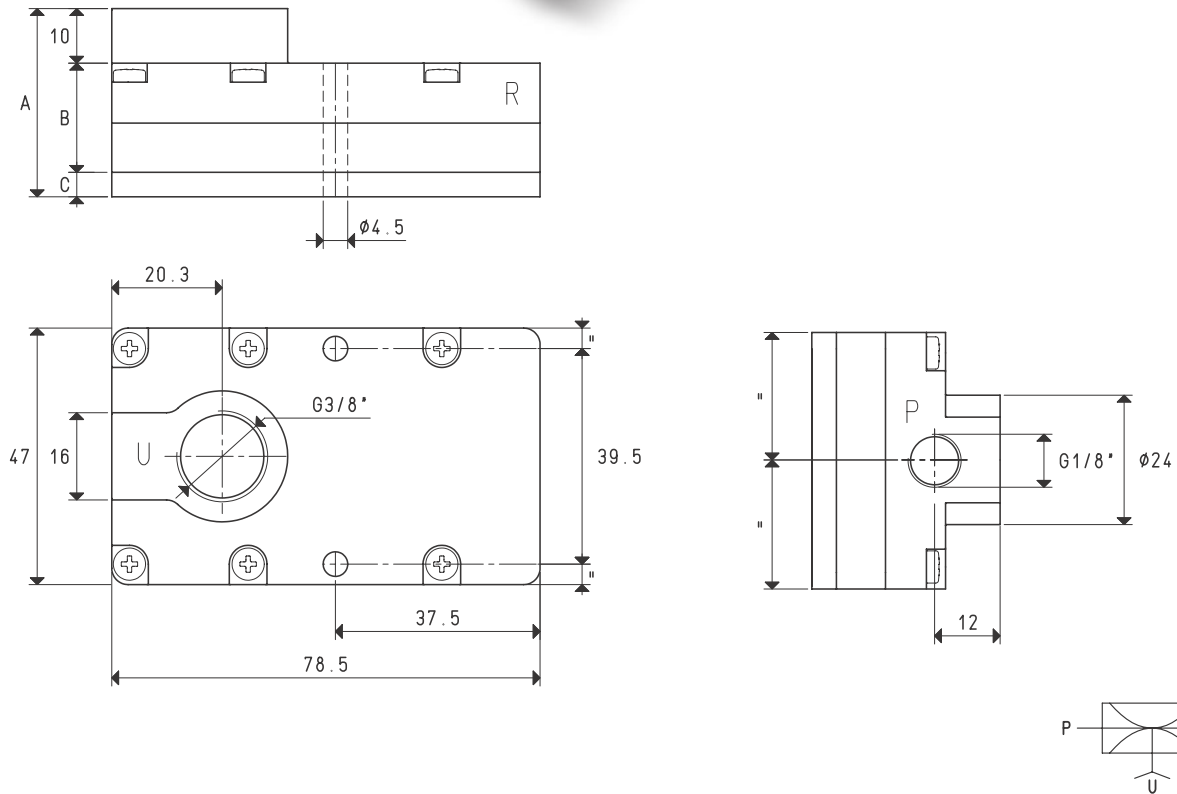

MULTI-STAGE VACUUM GENERATORS M 10, M 14 and M 18

3D drawings are available on vuototecnica.net



P=COMPRESSED AIR CONNECTION R=EXHAUST U=VACUUM CONNECTION

Item		M 10			M 14			M 18		
Intake air flow rate	m ³ /h	7.7	8.5	9.4	10.2	11.6	12.6	14.8	16.5	18.0
Maximum level of vacuum	-KPa	62	82	85	62	82	85	62	82	85
Final pressure	mbar abs.	380	180	150	380	180	150	380	180	150
Supply pressure	bar	3	4	5	3	4	5	3	4	5
Optimal supply pressure	bar			5			5			5
Air consumption	NI/s	1.2	1.6	1.9	1.7	2.1	2.5	2.3	2.9	3.6
Operating temperature	°C			-10 / +80			-10 / +80			-10 / +80
Noise level at optimal supply pressure	dB(A)			72			72			76
Weight	g			144			145			150
A				34.5			34.5			44.5
B				20			20			30
C				4.5			4.5			4.5
Spare parts		M 10			M 14			M 18		
Sealing kit and reed valves	item	00 KIT M 10			00 KIT M 14			00 KIT M 18		
Exhaust silencer	item	N°2 00 15 150			N°2 00 15 150			N°3 00 15 150		

Note: All vacuum values indicated in the table are valid at the normal atmospheric pressure of 1013 mbar and obtained with a constant supply pressure.

Vacuum generator supply must be carried out with non-lubricated compressed air, 5 micron filtration, in accordance with standard ISO 8573-1 class 4.

Transformation ratio: N (newton) = Kg x 9.81 (force of gravity)

inch = $\frac{\text{mm}}{25.4}$; pounds = $\frac{\text{g}}{453.6} = \frac{\text{Kg}}{0.4536}$

Adapters for GAS - NPT threading available on page 1.130



Air flow rate (NI/s) at different level of vacuum (-KPa) at optimal supply pressure

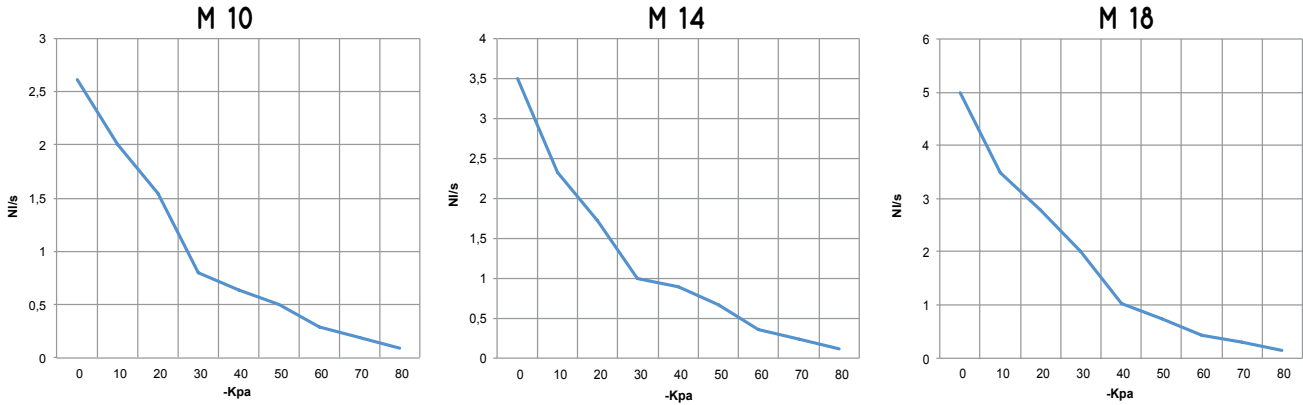

Generator item	Supp. press. bar	Air consumption NI/s	Air flow rate (NI/s) at different levels of vacuums (-KPa) at optimal supply pressure										Max vacuum -KPa
			0	10	20	30	40	50	60	70	80		
M 10	5.0	1.9	2.61	2.00	1.55	0.80	0.64	0.50	0.29	0.19	0.09	85	
M 14	5.0	2.5	3.50	2.33	1.72	1.00	0.89	0.67	0.35	0.24	0.11	85	
M 18	5.0	3.6	5.00	3.50	2.78	2.02	1.02	0.75	0.44	0.30	0.14	85	

Evacuation rates (ms/l = s/m³) at different levels of vacuums (-KPa) at optimal supply pressure

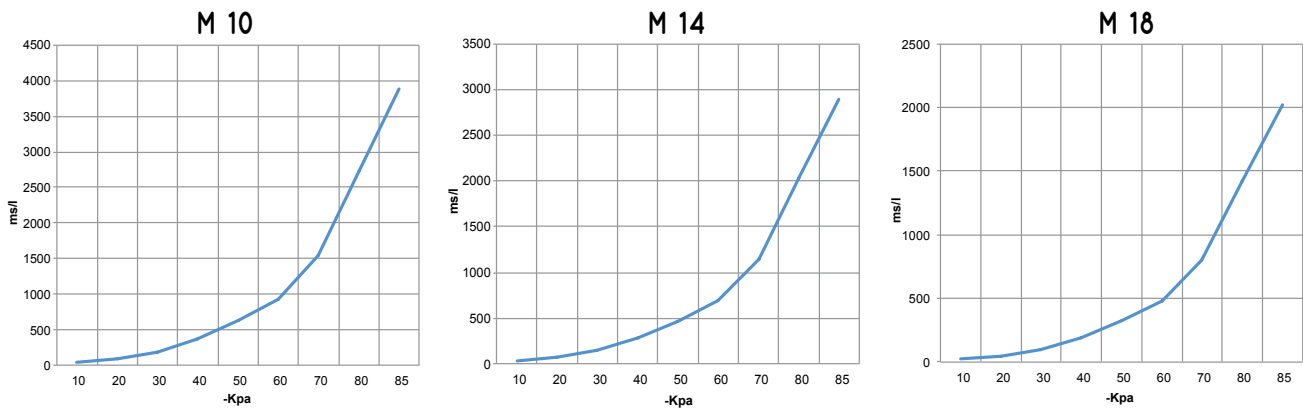

Generator item	Supp. press. bar	Air consumption NI/s	Evacuation rates (ms/l= s/m ³) at different levels of vacuums (-KPa) at optimal supply pressure										Max vacuum -KPa
			10	20	30	40	50	60	70	80	85		
M 10	5.0	1.9	40	93	188	371	629	918	1534	2731	3878	85	
M 14	5.0	2.5	30	69	140	276	469	685	1144	2036	2892	85	
M 18	5.0	3.6	21	48	98	193	327	478	799	1423	2020	85	