

# cilindri compatti ISO 21287

compact cylinders ISO 21287



- Realizzati secondo la normativa ISO 21287; possibilità di interassi UNITOP  
*The cylinders are compliant to norm ISO 21287; possibility to have fixing dimensions compliant to norm UNITOP*
- Grande affidabilità e lunga durata  
*High reliability and long life time*
- Versione magnetica standard  
*Standard magnetic version*
- Esecuzioni e corse speciali a richiesta  
*Special versions and strokes on request*



## Materiali

Camicia: alluminio

Stelo: C45 cromato o INOX AISI 304

Testate: alluminio

Pistone: alluminio

Guarnizioni pistone: NBR o VITON

Guarnizione stelo: poliuretano o VITON

Magnete: plastroferrite (non adatto per temperature oltre +60°C)

## Materials

Barrel: aluminium

Piston-rod: C45 (chromium plated) or stainless steel

End-cups: aluminium

Piston: aluminium

Piston sealings: NBR or VITON

Piston-rod sealing: polyurethane or VITON

Magnet: magnetic iron compound (not suitable for temperatures over +60°C)

Pressione di esercizio <i>Working pressure</i>	max 10 bar max 1 MPa
Temperatura di esercizio <i>Temperature range</i>	standard (poliuretano/NBR): max +60°C VITON: max +110°C
Alesaggi <i>Bores</i>	25; 32; 40; 50; 63; 80; 100 mm
Tipo di costruzione <i>Construction type</i>	Profilo quadro con cava a T su tre lati <i>Square aluminium profile with T-slot on three sides</i>
Corse <i>Strokes</i>	5 ... 200 mm
Fluido <i>Fluid</i>	Aria filtrata 50µ con o senza lubrificazione <i>50µ filtered, lubricated or non lubricated air</i>



## chiave di codifica

key to codes

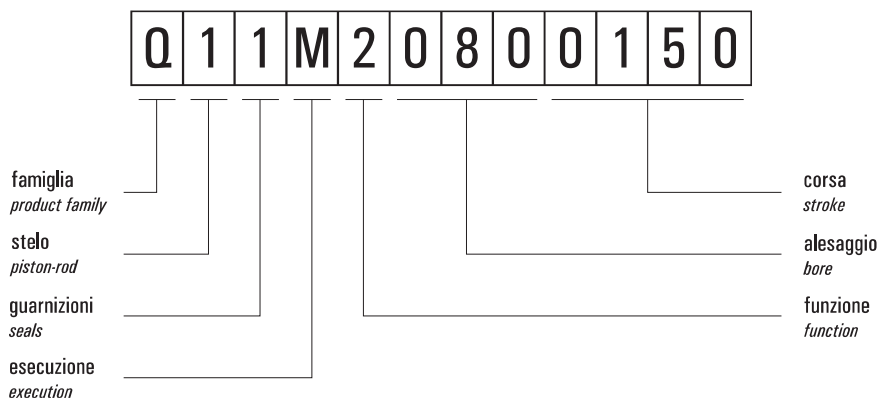

### Famiglia [product family]

- Q** cilindri compatti interasse ISO 21287  
*[compact cylinders with fixing distances ISO 21287]*
- U** cilindri compatti interasse UNITOP  
*[compact cylinders with fixing distances UNITOP]*

### Stelo [piston-rod]

- 1** C45 cromato - filetto stelo femmina  
*[C45 chromium plated - female rod thread]*
- 2** INOX - filetto stelo femmina  
*[stainless steel - female rod thread]*
- 3** C45 cromato - filetto stelo maschio  
*[C45 chromium plated - male rod thread]*
- 4** INOX - filetto stelo maschio  
*[stainless steel - male rod thread]*

### Guarnizioni [seals]

- 1** poliuretano [polyurethane]
- 2** tutte le guarnizioni in VITON [all seals in VITON]  
Attenzione: con questo tipo di guarnizioni per applicazioni ad alta temperatura, il pistone è non magnetico  
*[Attention: with this type of seals for high temperature applications, the piston is non-magnetic]*
- 3** guarnizioni dello stelo in VITON [rod seals in VITON]

### Esecuzione [execution]

- M** magnetico [magnetic]
- S** non magnetico [non-magnetic]
- D** magnetico contrapposto [magnetic opposite]
- F** magnetico, tandem in spinta stelo comune  
*[magnetic tandem cylinder, one piston rod]*
- H** magnetico, tandem in spinta steli indipendenti a due posizioni  
*[magnetic tandem cylinder, independent piston rods, two positions]*
- P** magnetico, tandem a tripla spinta stelo comune  
*[magnetic tandem cylinder, one piston rod, triple pushing]*
- L** magnetico antirotazione [magnetic anti-rotation]
- Q** magnetico basso attrito [magnetic low friction]
- R** magnetico, tandem in spinta steli indipendenti a tre posizioni  
*[magnetic tandem cylinder, independent piston rods, three positions]*

### Funzione [function]

- 1** semplice effetto non ammortizzato molla anteriore  
*[single acting front spring without pneumatic cushioning]*
- 2** doppio effetto non ammortizzato  
*[double acting without pneumatic cushioning]*
- 3** semplice effetto non ammortizzato molla posteriore  
*[single acting back spring without pneumatic cushioning]*
- 4** doppio effetto non ammortizzato stelo passante  
*[double acting without pneumatic cushioning, with passing-through rod]*
- 5** semplice effetto non ammortizzato stelo passante  
*[single acting without pneumatic cushioning, with passing-through rod]*
- 8** doppio effetto non ammortizzato stelo passante forato  
*[double acting without pneum. cushioning, perforated passing-through rod]*

# cilindri compatti ISO 21287

compact cylinders ISO 21287



## versioni disponibili

available versions

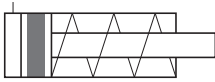
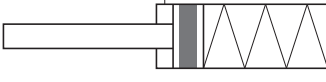
<b>semplice effetto molla anteriore</b> <i>single acting front spring</i> <b>magnetico</b> <i>magnetic</i> <b>non ammortizzato</b> <i>without pneumatic cushioning</i>	alesaggio		25	32	40	50	63	80	100	<b>OPZIONI</b> <i>options</i>  Lo standard è evidenziato in grigio <i>The standard is marked with grey background</i>				
	corsa	bore									stroke			
	5	X	X	X	X	X	X	X	X		<b>materiale stelo [piston-rod material]</b> C45 cromato <i>C45 chromium plated</i>	<b>INOX</b> <i>stainless steel</i>		
	10	X	X	X	X	X	X	X	X				<b>materiale guarnizioni [seals material]</b>  poliuret.    tutte in VITON <i>all seals in VITON</i>	guarnizioni stelo in VITON <i>rod seals in VITON</i>
	25	X	X	X	X	X	X	X	X			<b>filetto stelo [rod thread]</b>  filetto stelo femmina <i>female rod thread</i>		
	30			X	X	X	X	X	X					
	40													
	50													
	75													
	80													
	100													
	125													
	150													
	160													
	200													
	<b>semplice eff. molla posteriore</b> <i>single acting back spring</i> <b>magnetico</b> <i>magnetic</i> <b>non ammortizzato</b> <i>without pneumatic cushioning</i>	alesaggio		25	32	40	50	63	80	100		<b>OPZIONI</b> <i>options</i>  Lo standard è evidenziato in grigio <i>The standard is marked with grey background</i>		
corsa	bore	stroke												
	5	X	X	X	X	X	X	X	X	<b>materiale stelo [piston-rod material]</b> C45 cromato <i>C45 chromium plated</i>	<b>INOX</b> <i>stainless steel</i>			
	10	X	X	X	X	X	X	X	X				<b>materiale guarnizioni [seals material]</b>  poliuret.    tutte in VITON <i>all seals in VITON</i>	guarnizioni stelo in VITON <i>rod seals in VITON</i>
	25	X	X	X	X	X	X	X	X		<b>filetto stelo [rod thread]</b>  filetto stelo femmina <i>female rod thread</i>			
	30			X	X	X	X	X	X					
	40													
	50													
	75													
	80													
	100													
	125													
	150													
	160													
	200													

## versioni disponibili

available versions

<b>doppio effetto</b> <i>double acting</i> <b>magnetico</b> <i>magnetic</i> <b>non ammortizzato</b> <i>without pneumatic cushioning</i>	alesaggio		25	32	40	50	63	80	100	<b>OPZIONI</b> <i>options</i>  Lo standard è evidenziato in grigio <i>The standard is marked with grey background</i>		
	corsa	bore									stroke	
	5		X	X	X	X	X	X	X		<b>materiale stelo [piston-rod material]</b>  C45 cromato <i>C45 chromium plated</i> INOX <i>stainless steel</i>  <b>materiale guarnizioni [seals material]</b>  poliuret.      tutte in VITON <i>all seals in VITON</i> guarnizioni stelo <i>rod seals in VITON</i>  <b>filetto stelo [rod thread]</b>  filetto stelo femmina <i>female rod thread</i> filetto stelo maschio <i>male rod thread</i>	
	10		X	X	X	X	X	X	X			
	25		X	X	X	X	X	X	X			
	30		X	X	X	X	X	X	X			
	40		X	X	X	X	X	X	X			
	50		X	X	X	X	X	X	X			
	75		X	X	X	X	X	X	X			
	80		X	X	X	X	X	X	X			
	100		X	X	X	X	X	X	X			
	125		X	X	X	X	X	X	X			
	150		X	X	X	X	X	X	X			
	160		X	X	X	X	X	X	X			
	200		X	X	X	X	X	X	X			
	<b>doppio effetto</b> <i>double acting</i> <b>magnetico</b> <i>magnetic</i> <b>non ammortizzato</b> <i>without pneumatic cushioning</i> <b>stelo passante</b> <i>passing-through rod</i>	alesaggio		25	32	40	50	63	80	100		<b>OPZIONI</b> <i>options</i>  Lo standard è evidenziato in grigio <i>The standard is marked with grey background</i>
corsa		bore	stroke									
		5		X	X	X	X	X	X	X	<b>materiale stelo [piston-rod material]</b>  C45 cromato <i>C45 chromium plated</i> INOX <i>stainless steel</i>  <b>materiale guarnizioni [seals material]</b>  poliuret.      tutte in VITON <i>all seals in VITON</i> guarnizioni stelo <i>rod seals in VITON</i>  <b>filetto stelo [rod thread]</b>  filetto stelo femmina <i>female rod thread</i> filetto stelo maschio <i>male rod thread</i>	
		10		X	X	X	X	X	X	X		
		25		X	X	X	X	X	X	X		
		30		X	X	X	X	X	X	X		
		40		X	X	X	X	X	X	X		
		50		X	X	X	X	X	X	X		
		75		X	X	X	X	X	X	X		
		80		X	X	X	X	X	X	X		
		100		X	X	X	X	X	X	X		
		125		X	X	X	X	X	X	X		
		150		X	X	X	X	X	X	X		
		160		X	X	X	X	X	X	X		
	200		X	X	X	X	X	X	X			

6

# cilindri compatti ISO 21287

compact cylinders ISO 21287

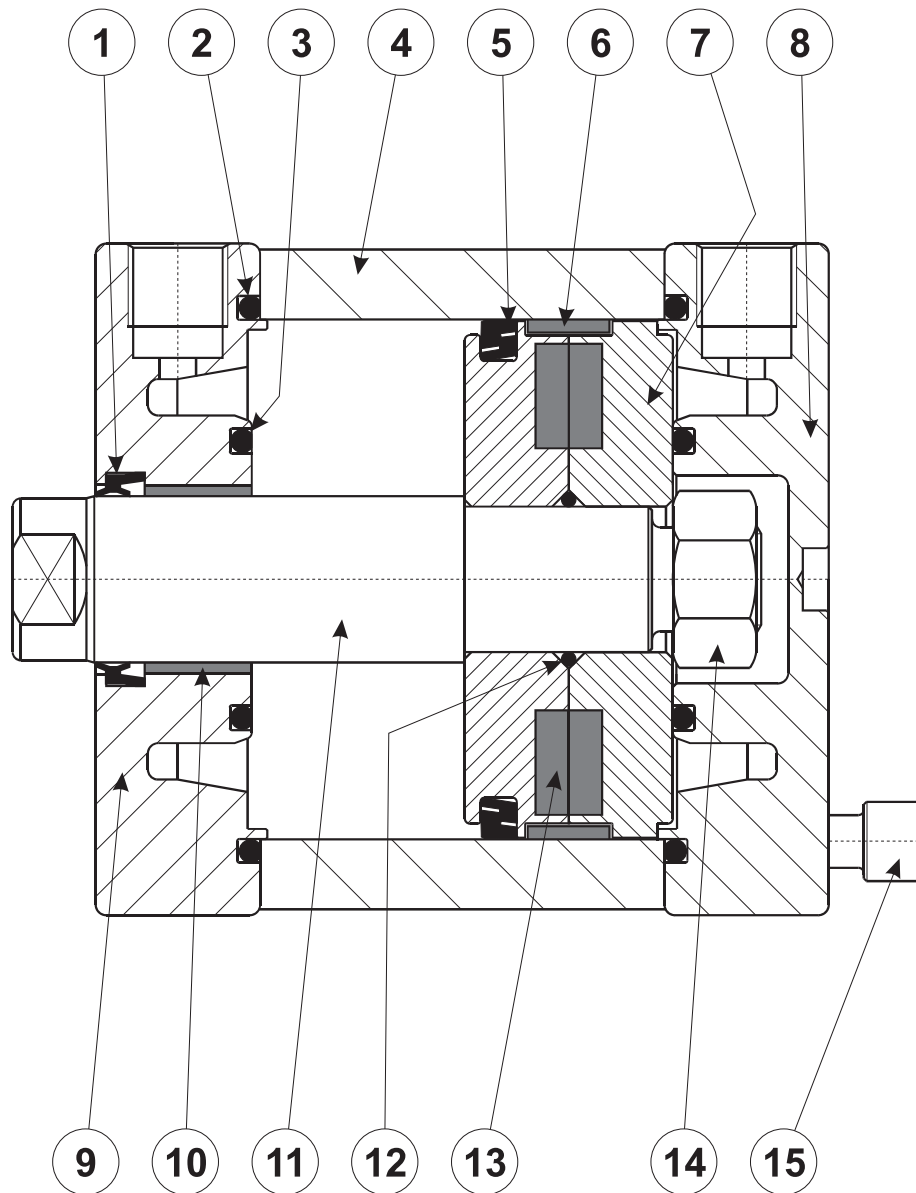

1. Guarnizione stelo: poliuretano o VITON
2. O-Ring per tenuta testata: NBR o VITON
3. O-Ring paracolpi: NBR o VITON
4. Camicia: alluminio profilato, calibrato e anodizzato
5. Guarnizione tenuta pistone: NBR o VITON
6. Anello guida per pistone: PTFE
7. Pistone: alluminio
8. Testata posteriore: alluminio anodizzato
9. Testata anteriore: alluminio anodizzato
10. Boccola guida stelo: materiale autolubrificante
11. Stelo: acciaio C45 cromato o INOX AISI 304
12. O-Ring per tenuta pistone: NBR o VITON
13. Magnete:  $\varnothing 25$  neodimio;  $\varnothing 32-100$  plastoferrite
14. Dado per bloccaggio stelo: acciaio zincato
15. Vite autofilettante per fissaggio testata: acciaio zincato



## KIT GUARNIZIONI DI RICAMBIO

seals kit

MAGNETICO, guarnizioni standard					
normale			stelo passante <i>[passing-through rod]</i>		
per alesaggio <i>for bore</i>	sigla <i>part number</i>	codice <i>code</i>	per alesaggio <i>for bore</i>	sigla <i>part number</i>	codice <i>code</i>
25	<b>GQ025</b>	39.102.2	25	<b>GQ025P</b>	39.112.2
32	<b>GQ032</b>	39.103.2	32	<b>GQ032P</b>	39.113.2
40	<b>GQ040</b>	39.104.2	40	<b>GQ040P</b>	39.114.2
50	<b>GQ050</b>	39.105.2	50	<b>GQ050P</b>	39.115.2
63	<b>GQ063</b>	39.106.2	63	<b>GQ063P</b>	39.116.2
80	<b>GQ080</b>	39.107.2	80	<b>GQ080P</b>	39.117.2
100	<b>GQ100</b>	39.108.2	100	<b>GQ100P</b>	39.118.2

  

MAGNETICO, guarnizioni VITON					
normale			stelo passante <i>[passing-through rod]</i>		
per alesaggio <i>for bore</i>	sigla <i>part number</i>	codice <i>code</i>	per alesaggio <i>for bore</i>	sigla <i>part number</i>	codice <i>code</i>
25	<b>GQ025V</b>	39.122.2	25	<b>GQ025PV</b>	39.132.2
32	<b>GQ032V</b>	39.123.2	32	<b>GQ032PV</b>	39.133.2
40	<b>GQ040V</b>	39.124.2	40	<b>GQ040PV</b>	39.134.2
50	<b>GQ050V</b>	39.125.2	50	<b>GQ050PV</b>	39.135.2
63	<b>GQ063V</b>	39.126.2	63	<b>GQ063PV</b>	39.136.2
80	<b>GQ080V</b>	39.127.2	80	<b>GQ080PV</b>	39.137.2
100	<b>GQ100V</b>	39.128.2	100	<b>GQ100PV</b>	39.138.2

6

## VERSIONE MAGNETICA, FILETTO STELO FEMMINA, ALESAGGIO 25 mm

magnetic version, female rod thread, bore 25 mm

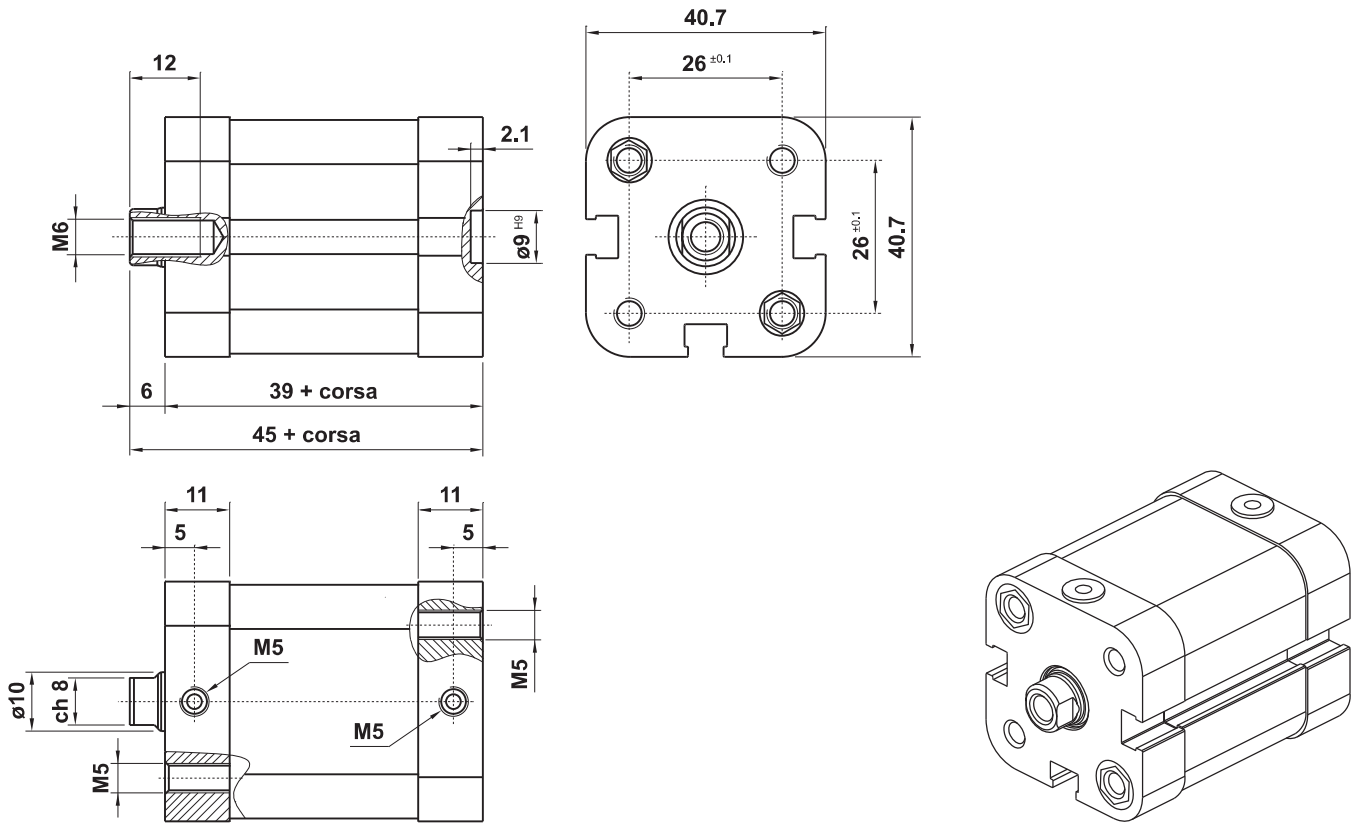

6

## VERSIONE MAGNETICA, FIL. STELO FEMMINA, STELO PASS., ALES. 25 mm

magnetic version, female rod thread, passing-through rod, bore 25 mm

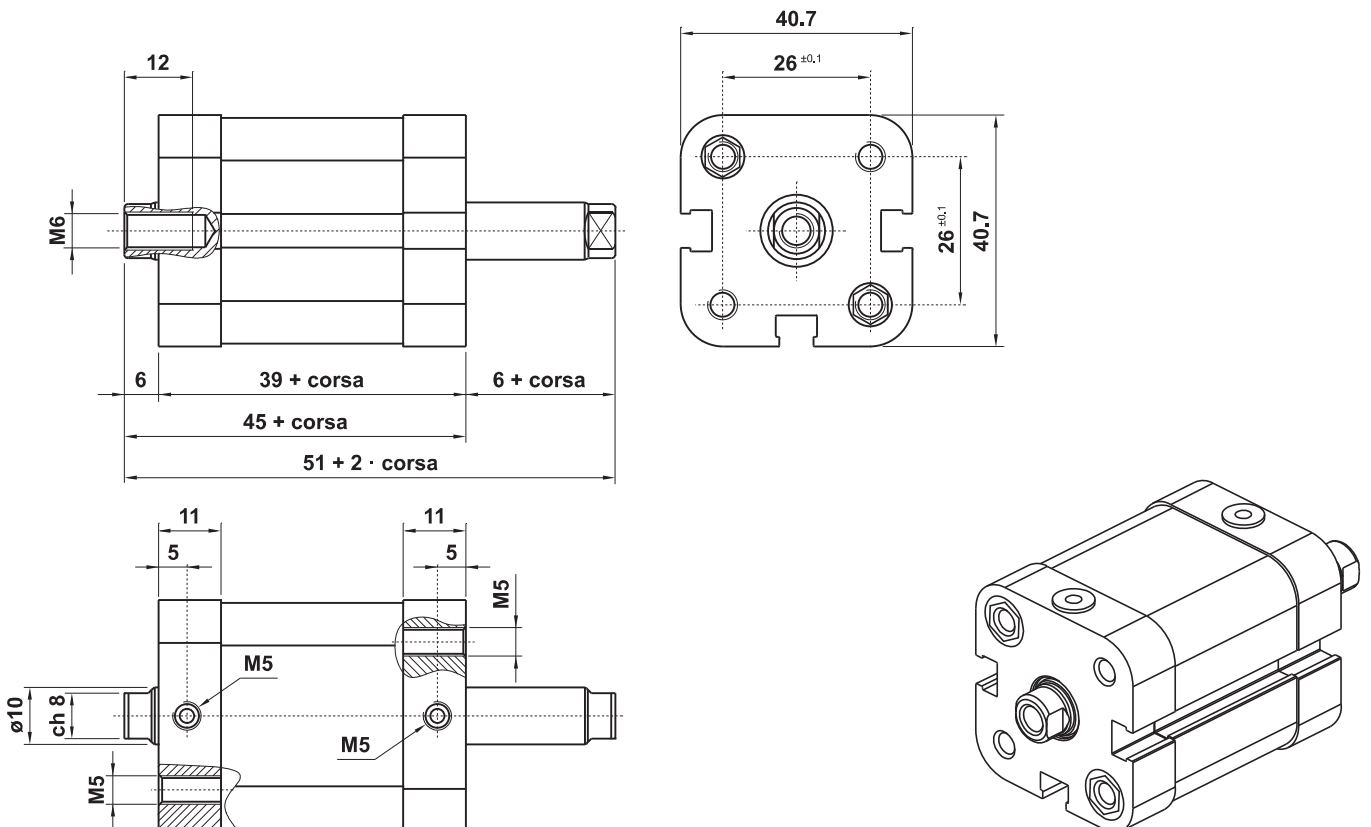

# cilindri compatti ISO 21287

compact cylinders ISO 21287



## VERSIONE MAGNETICA, FILETTO STELO MASCHIO, ALESAGGIO 25 mm

magnetic version, male rod thread, bore 25 mm

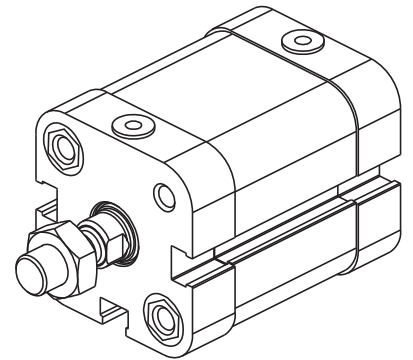
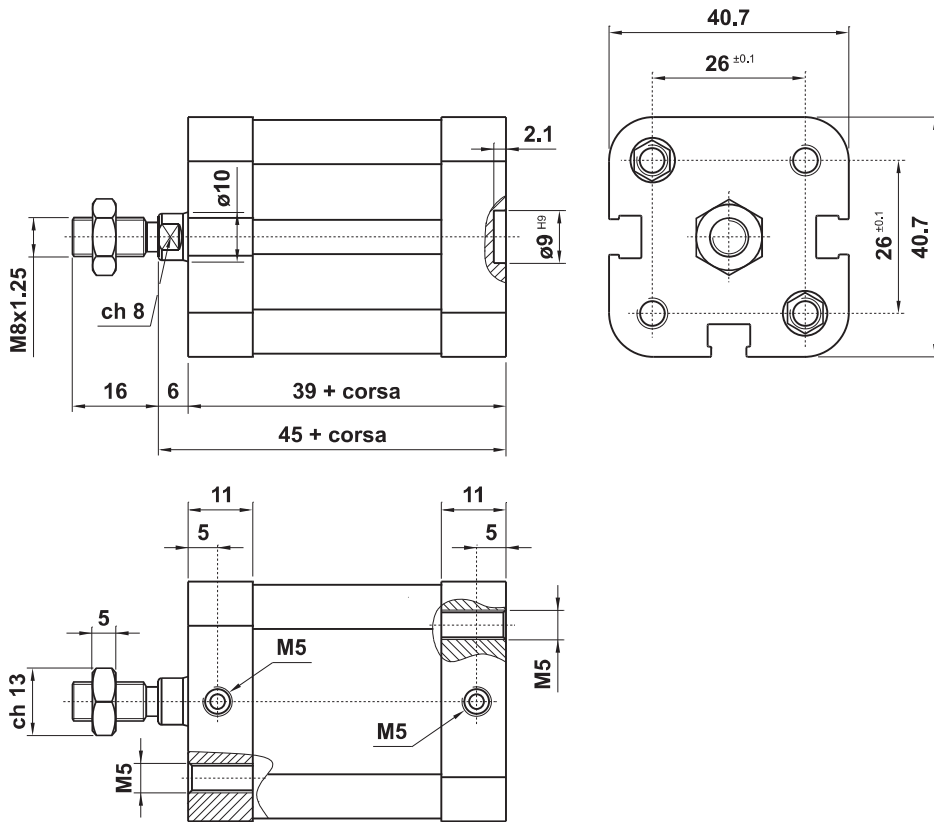

## VERSIONE MAGNETICA, FIL. STELO MASCHIO, STELO PASS., ALES. 25 mm

magnetic version, male rod thread, passing-through rod, bore 25 mm

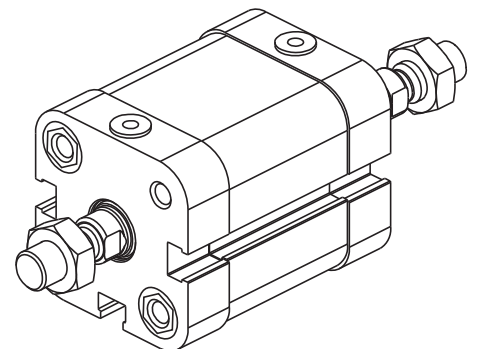
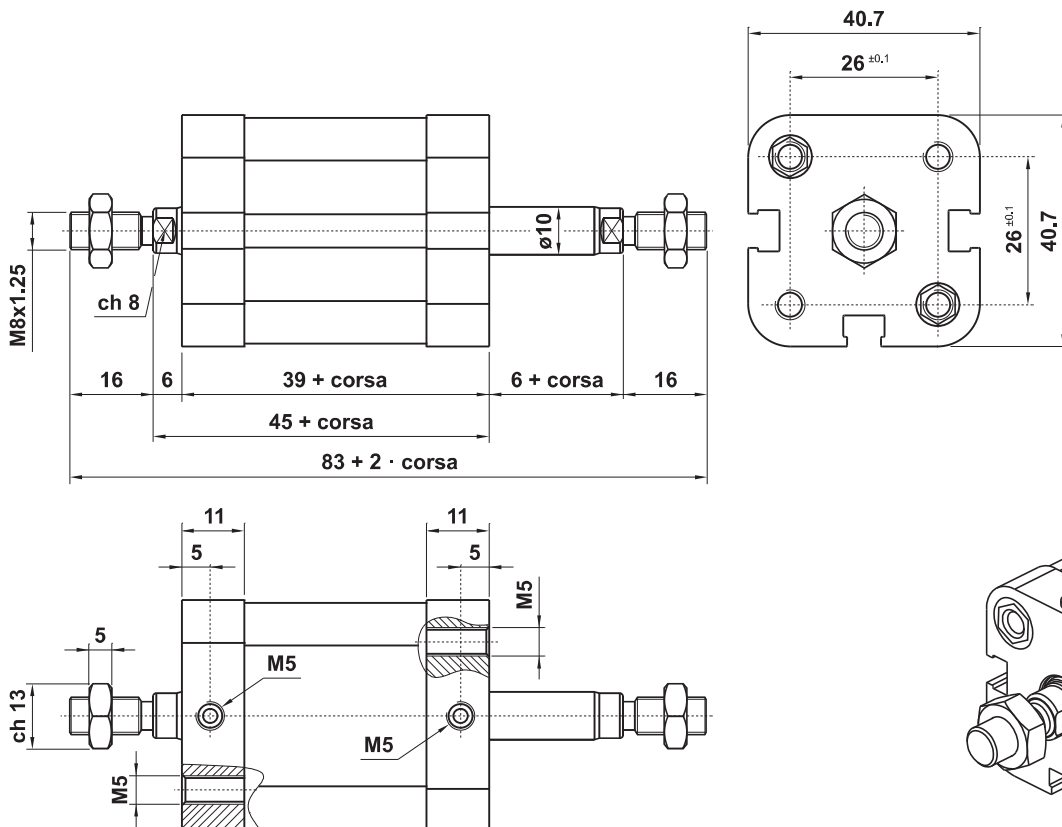



# cilindri compatti ISO 21287

compact cylinders ISO 21287



## VERSIONE MAGNETICA, ANTIROTAZIONE, ALESAGGIO 25 mm

magnetic version, anti-rotation, bore 25 mm

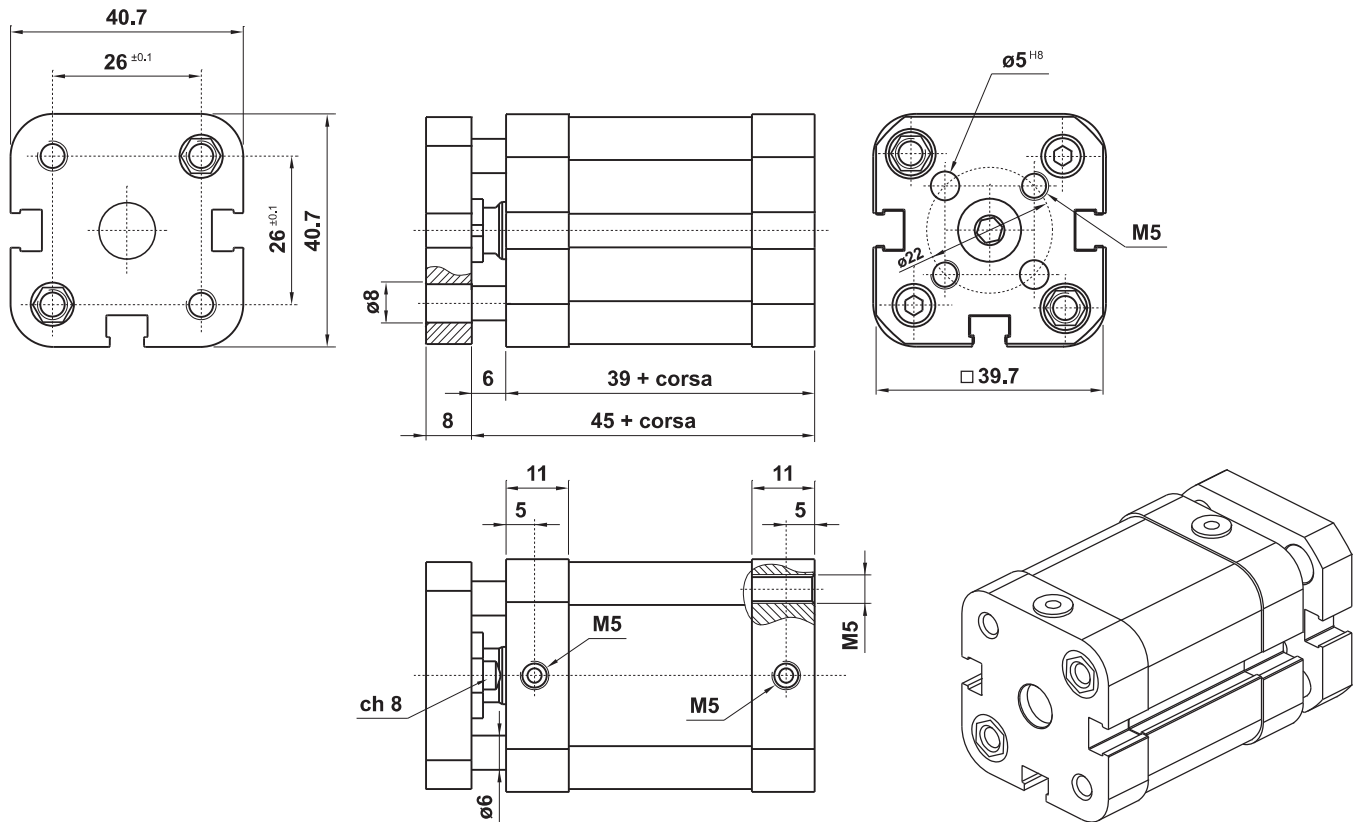

## VERSIONE MAGNETICA, ANTIROTAZIONE, STELO PASS., ALESAGGIO 25 mm

magnetic version, anti-rotation, passing-through rod, bore 25 mm

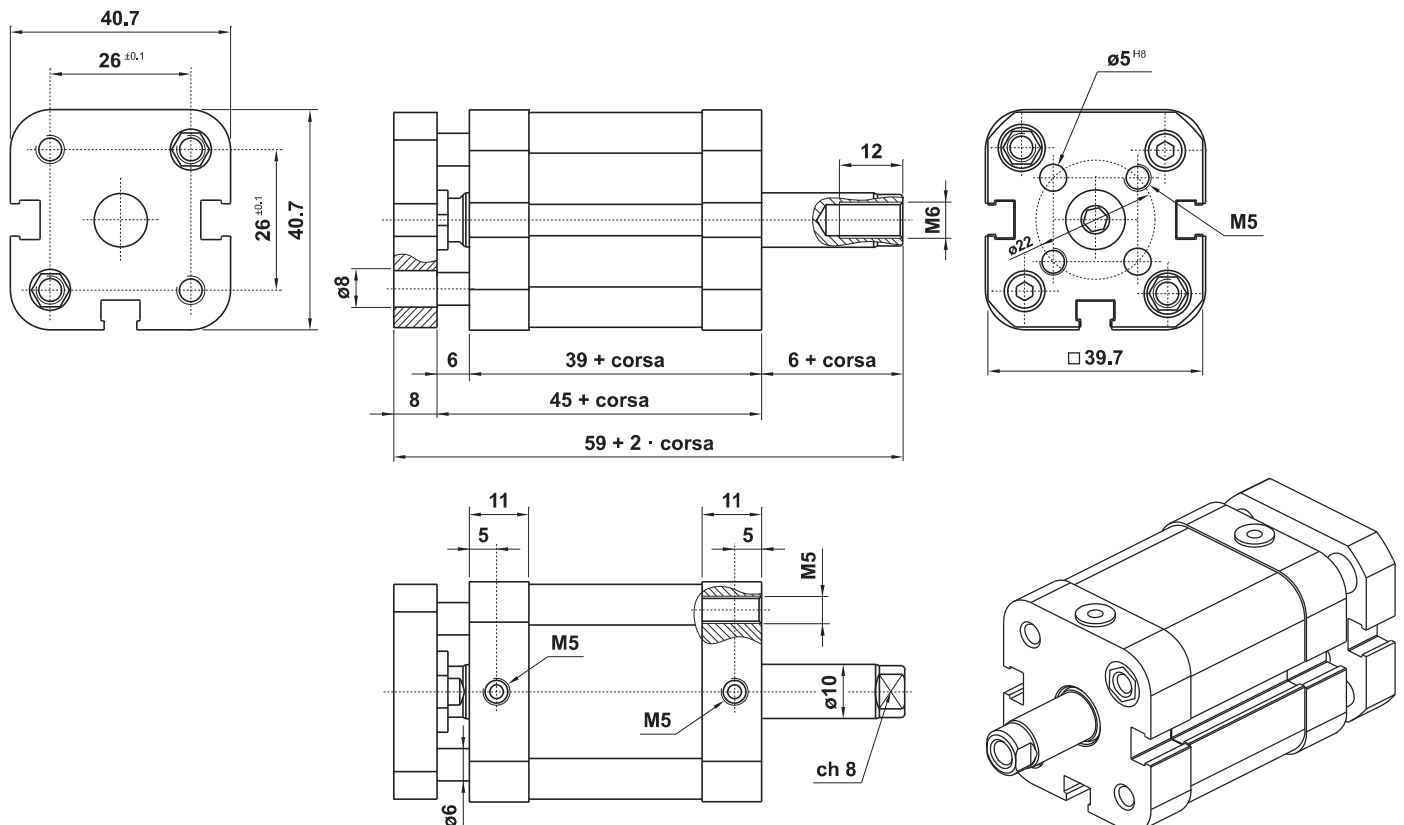



## VERSIONE MAGNETICA, FILETTO STELO FEMMINA

magnetic version, female rod thread

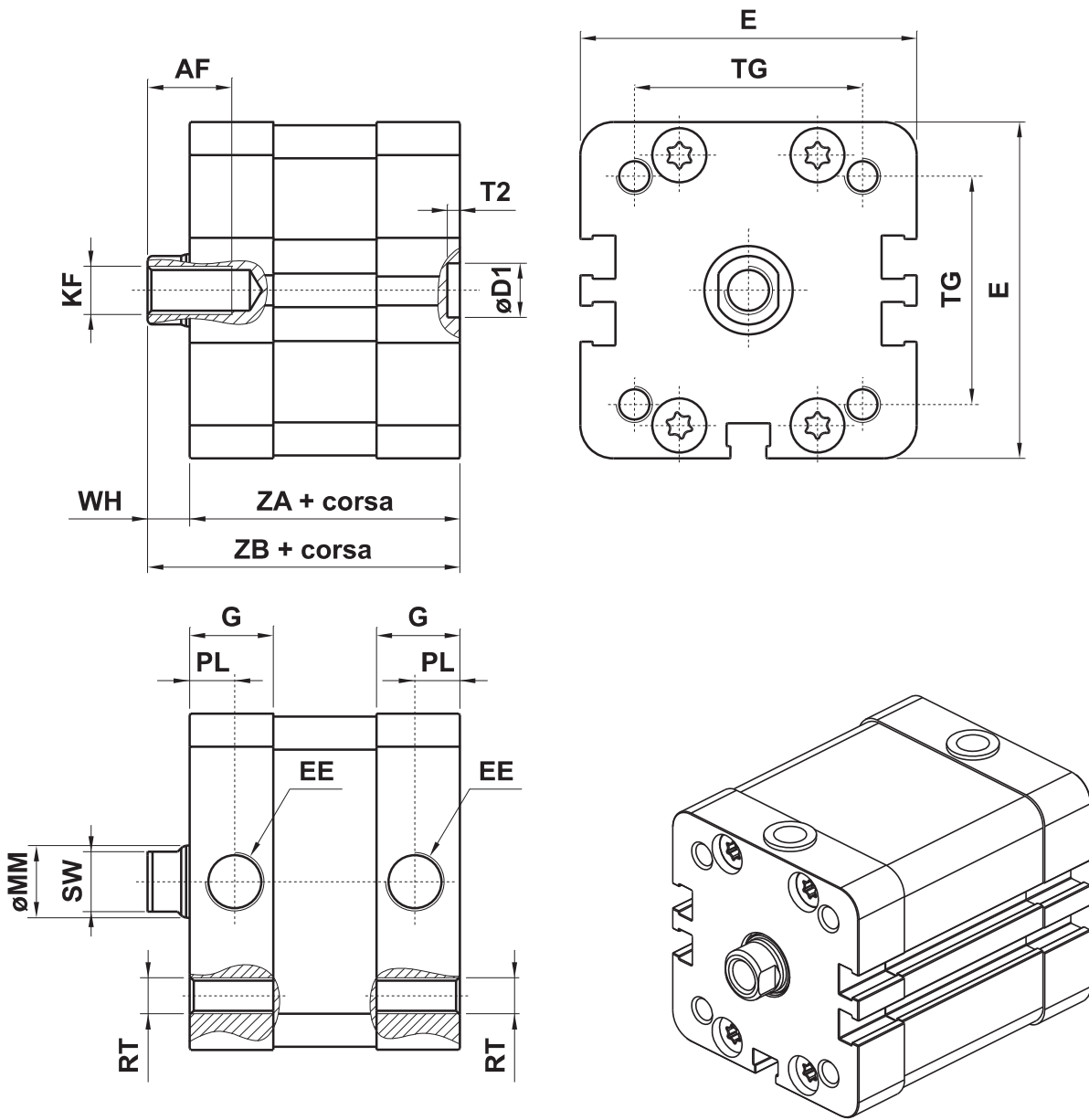

6

### ISO 21287

ø	AF	øD1 <sub>H9</sub>	E	EE	G	KF	øMM	PL	RT	SW	TG ±0.1		T2	WH	ZA	ZB
											ISO	UNITOP				
32	14	9	49	G1/8"	13.9	M8	12	7.5	M6	ch 10	32.5	32.5	2.1	7	44	51
40	14	9	56	G1/8"	14.7	M8	12	7.5	M6	ch 10	38	42	2.1	7	45	52
50	16	12	69	G1/8"	14.3	M10	16	7.5	M8	ch 13	46.5	50	2.6	8	45	53
63	16	12	79	G1/8"	15.8	M10	16	7.5	M8	ch 13	56.5	62	2.6	8	49	57
80	20	12	95	G1/8"	16.4	M12	20	7.5	M10	ch 17	72	82	2.6	10	54	64
100	24	12	115.5	G1/8"	17.5	M12	25	7.5	M10	ch 22	89	103	2.6	10	67	77

# cilindri compatti ISO 21287

compact cylinders ISO 21287



## VERSIONE MAGNETICA, FILETTO STELO MASCHIO

magnetic version, male rod thread

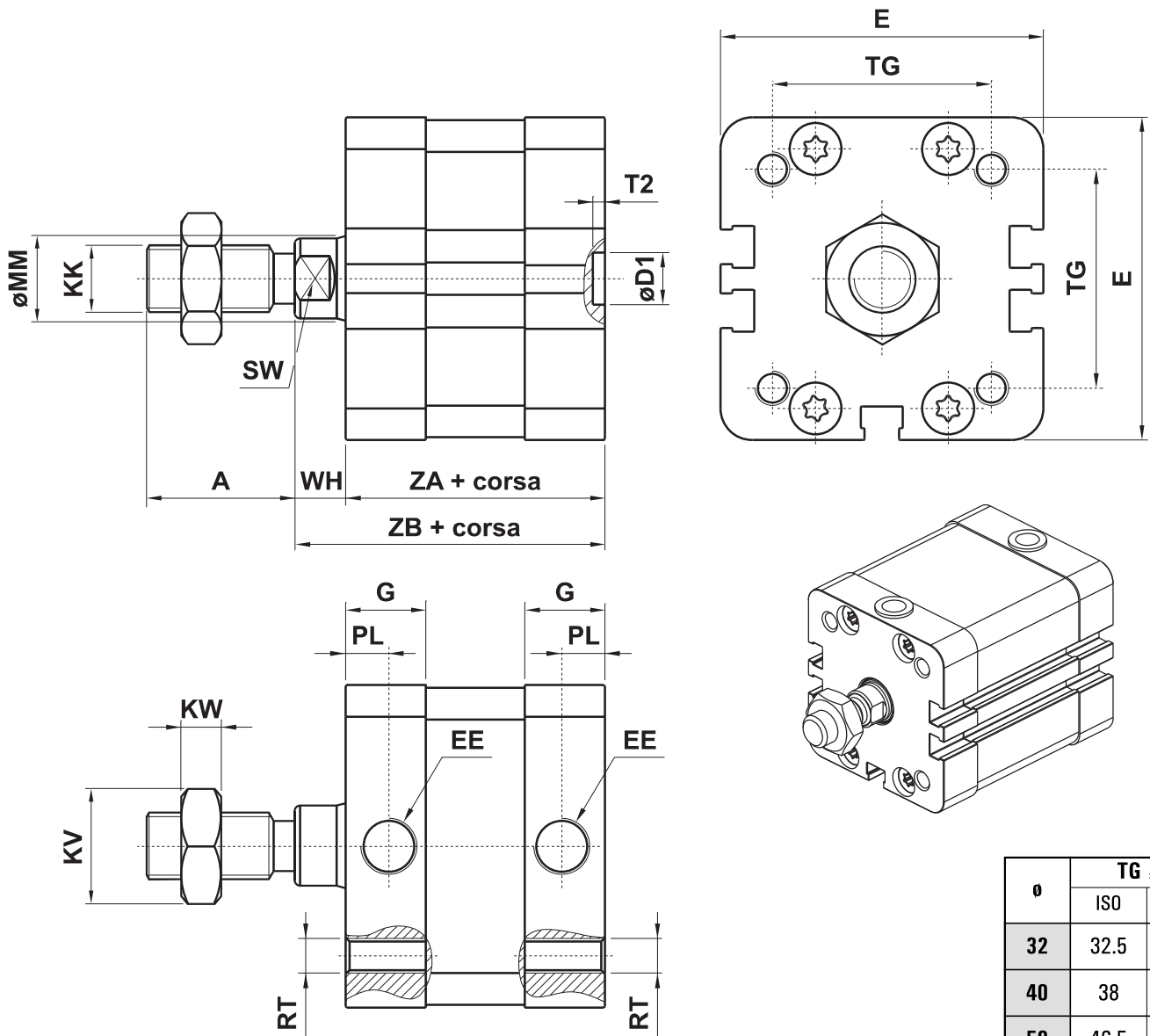

ø	TG ±0.1	
	ISO	UNITOP
32	32.5	32.5
40	38	42
50	46.5	50
63	56.5	62
80	72	82
100	89	103

### ISO 21287

ø	A	øD1 H9	E	EE	G	KK	KV	KW	øMM	PL	RT	SW	T2	WH	ZA	ZB
32	19	9	49	G1/8"	13.9	M10x1.25	ch 17	6	12	7.5	M6	ch 10	2.1	7	44	51
40	19	9	56	G1/8"	14.7	M10x1.25	ch 17	6	12	7.5	M6	ch 10	2.1	7	45	52
50	22	12	69	G1/8"	14.3	M12x1.25	ch 19	7	16	7.5	M8	ch 13	2.6	8	45	53
63	22	12	79	G1/8"	15.8	M12x1.25	ch 19	7	16	7.5	M8	ch 13	2.6	8	49	57
80	28	12	95	G1/8"	16.4	M16x1.5	ch 24	8	20	7.5	M10	ch 17	2.6	10	54	64
100	28	12	115.5	G1/8"	17.5	M16x1.5	ch 24	8	25	7.5	M10	ch 22	2.6	10	67	77

# cilindri compatti ISO 21287

compact cylinders ISO 21287



## VERSIONE MAGNETICA, FILETTO STELO FEMMINA, STELO PASSANTE

magnetic version, female rod thread, passing-through rod

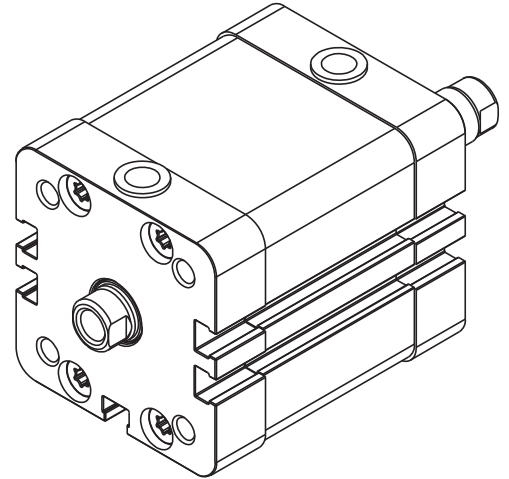
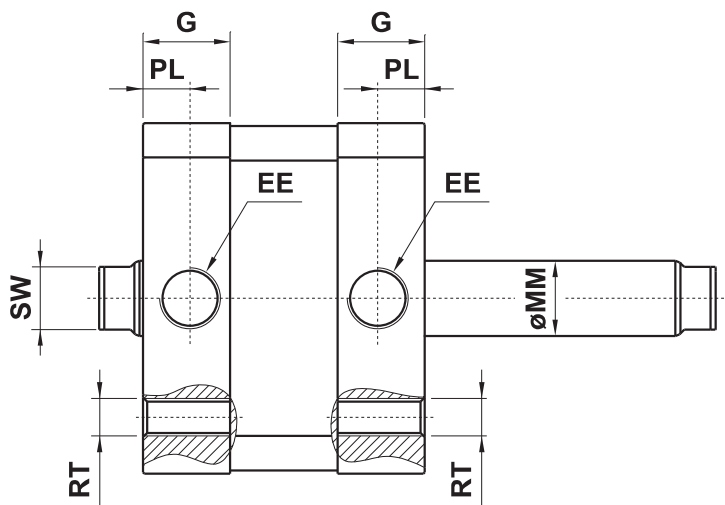
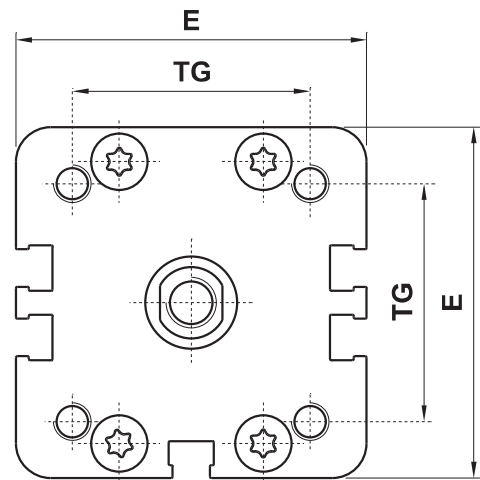
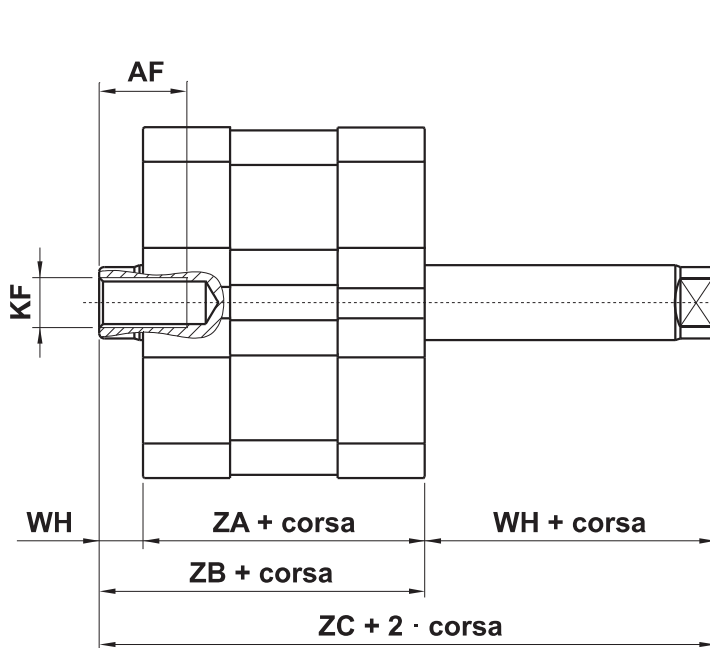

### ISO 21287

ø	AF	E	EE	G	KF	øMM	PL	RT	SW	TG ±0.1		WH	ZA	ZB	ZC
										ISO	UNITOP				
32	14	49	G1/8"	13.9	M8	12	7.5	M6	ch 10	32.5	32.5	7	44	51	58
40	14	56	G1/8"	14.7	M8	12	7.5	M6	ch 10	38	42	7	45	52	59
50	16	69	G1/8"	14.3	M10	16	7.5	M8	ch 13	46.5	50	8	45	53	61
63	16	79	G1/8"	15.8	M10	16	7.5	M8	ch 13	56.5	62	8	49	57	65
80	20	95	G1/8"	16.4	M12	20	7.5	M10	ch 17	72	82	10	54	64	74
100	24	115.5	G1/8"	17.5	M12	25	7.5	M10	ch 22	89	103	10	67	77	87

# cilindri compatti ISO 21287

compact cylinders ISO 21287



## VERSIONE MAGNETICA, FILETTO STELO MASCHIO, STELO PASSANTE

magnetic version, male rod thread, passing-through rod

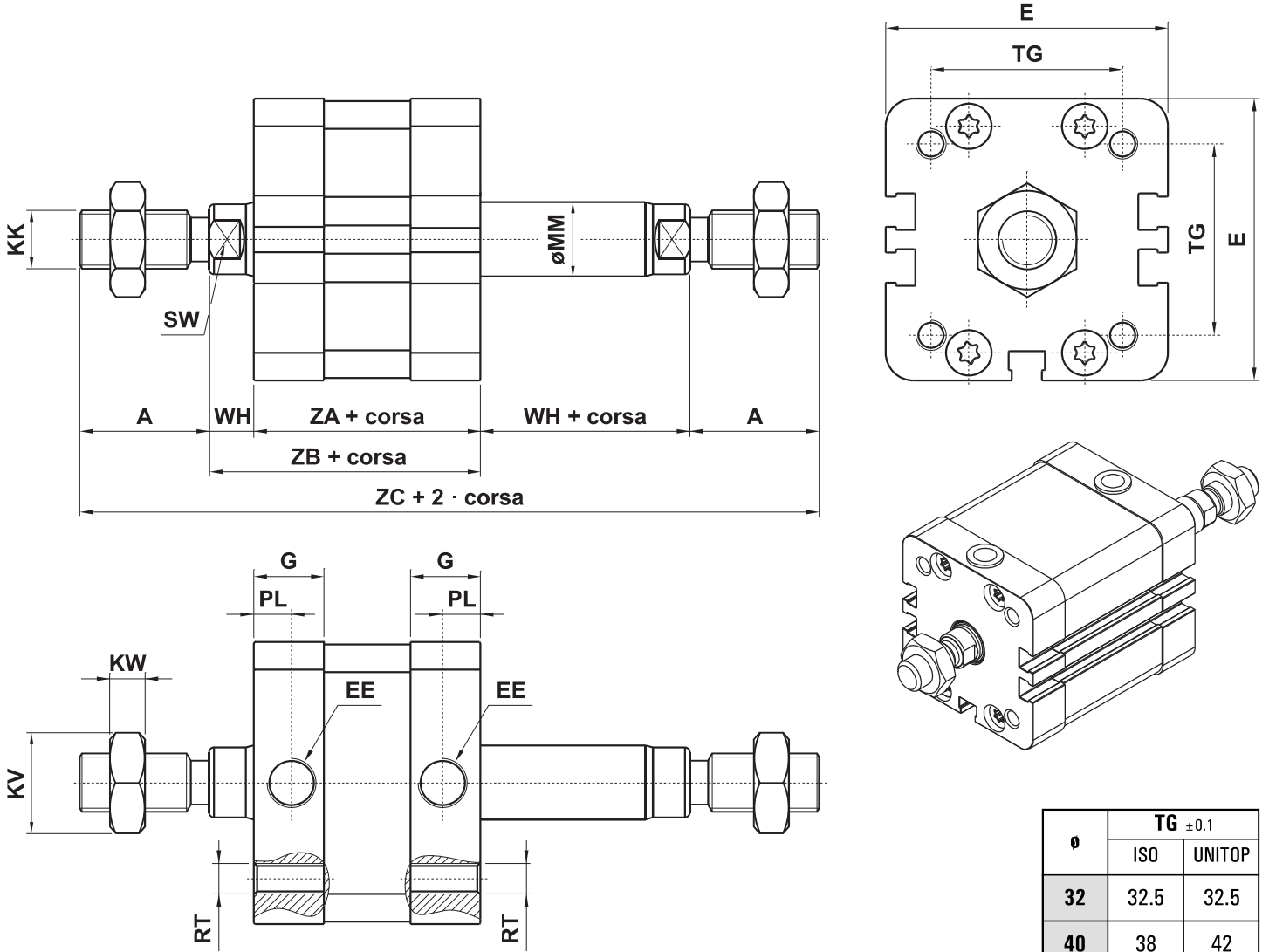

### ISO 21287

ø	TG ±0.1	
	ISO	UNITOP
32	32.5	32.5
40	38	42
50	46.5	50
63	56.5	62
80	72	82
100	89	103

ø	A	E	EE	G	KK	KV	KW	øMM	PL	RT	SW	WH	ZA	ZB	ZC
32	19	49	G1/8"	13.9	M10x1.25	ch 17	6	12	7.5	M6	ch 10	7	44	51	96
40	19	56	G1/8"	14.7	M10x1.25	ch 17	6	12	7.5	M6	ch 10	7	45	52	97
50	22	69	G1/8"	14.3	M12x1.25	ch 19	7	16	7.5	M8	ch 13	8	45	53	105
63	22	79	G1/8"	15.8	M12x1.25	ch 19	7	16	7.5	M8	ch 13	8	49	57	109
80	28	95	G1/8"	16.4	M16x1.5	ch 24	8	20	7.5	M10	ch 17	10	54	64	130
100	28	115.5	G1/8"	17.5	M16x1.5	ch 24	8	25	7.5	M10	ch 22	10	67	77	143

# cilindri compatti ISO 21287

compact cylinders ISO 21287



## VERSIONE MAGNETICA, ANTIROTAZIONE

magnetic version, anti-rotation

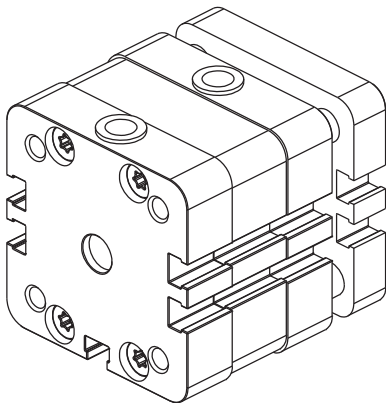
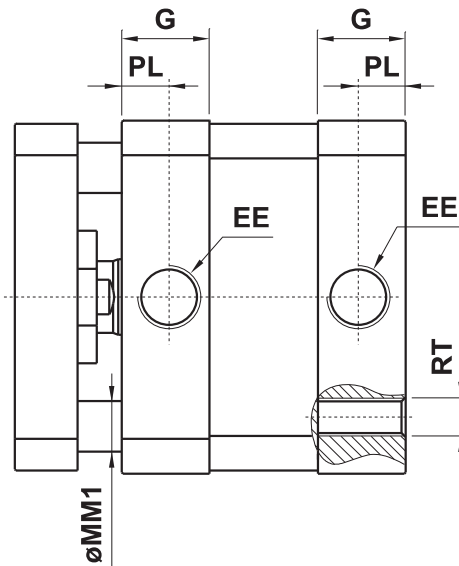
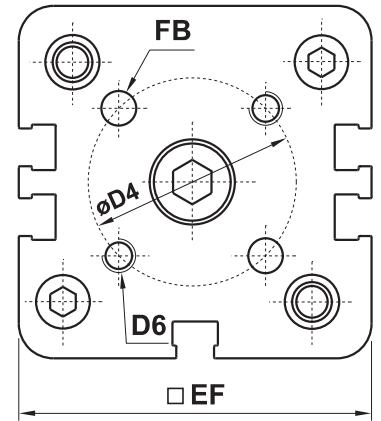
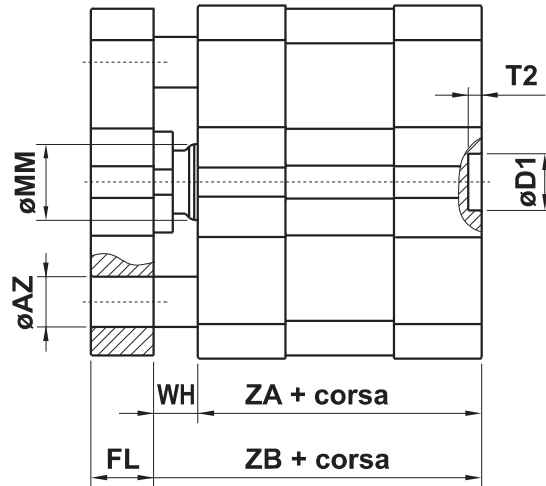
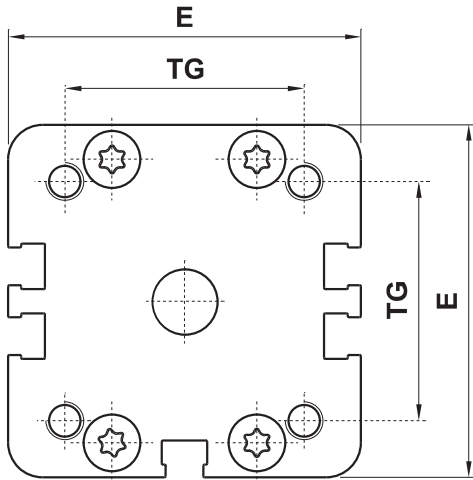

ø	TG ±0.1	
	ISO	UNITOP
32	32.5	32.5
40	38	42
50	46.5	50
63	56.5	62
80	72	82
100	89	103

### ISO 21287

ø	øAZ	øD1 <sub>H9</sub>	øD4	D6	E	EE	EF	øFB <sub>H8</sub>	FL	G	KF	øMM	øMM1	PL	RT	SW	T2	WH	ZA	ZB
32	8	9	28	M5	49	G1/8"	48.2	5	10	13.9	M8	12	6	7.5	M6	ch 10	2.1	7	44	51
40	8	9	33	M5	56	G1/8"	55	5	10	14.7	M8	12	8	7.5	M6	ch 10	2.1	7	45	52
50	11	12	42	M6	69	G1/8"	68	6	12	14.3	M10	16	10	7.5	M8	ch 13	2.6	8	45	53
63	11	12	50	M6	79	G1/8"	78	6	12	15.8	M10	16	10	7.5	M8	ch 13	2.6	8	49	57
80	15	12	65	M8	95	G1/8"	94	8	14	16.4	M12	20	12	7.5	M10	ch 17	2.6	10	54	64
100	15	12	80	M10	115.5	G1/8"	114.5	10	14	17.5	M12	25	12	7.5	M10	ch 22	2.6	10	67	77

# cilindri compatti ISO 21287

compact cylinders ISO 21287



## VERSIONE MAGNETICA, ANTIROTAZIONE, STELO PASSANTE

magnetic version, anti-rotation, passing-through rod

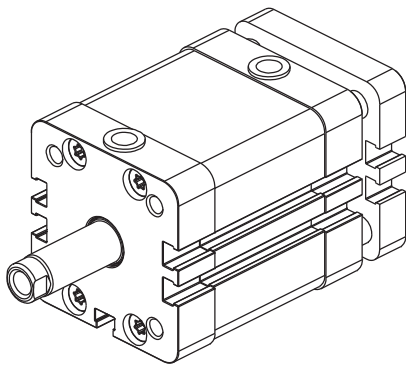
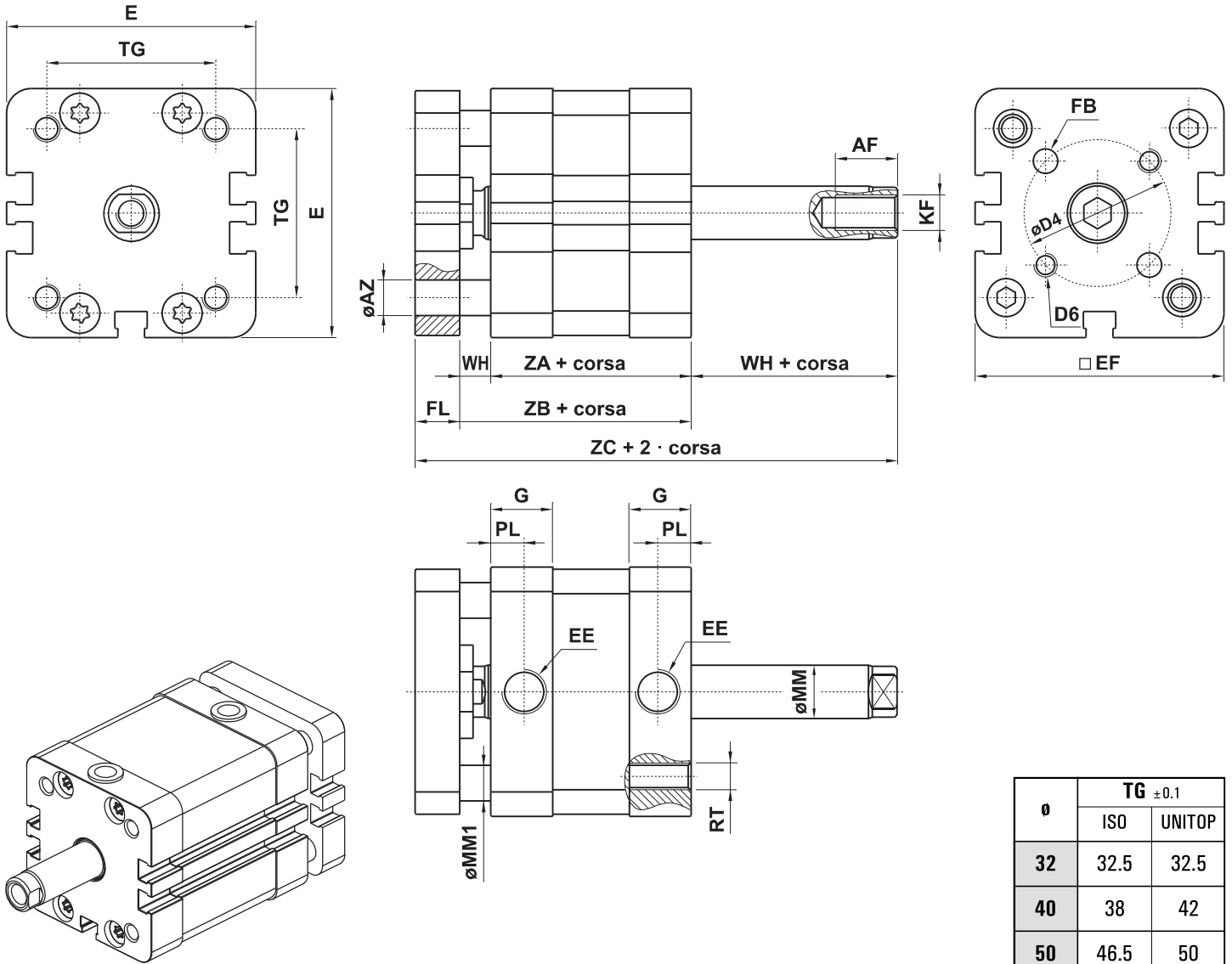

ø	TG ±0.1	
	ISO	UNITOP
32	32.5	32.5
40	38	42
50	46.5	50
63	56.5	62
80	72	82
100	89	103

### ISO 21287

ø	AF	øAZ	øD4	D6	E	EE	EF	øFB <sub>H8</sub>	FL	G	KF	øMM	øMM1	PL	RT	SW	WH	ZA	ZB	ZC
32	14	8	28	M5	49	G1/8"	48.2	5	10	13.9	M8	12	6	7.5	M6	ch 10	7	44	51	68
40	14	8	33	M5	56	G1/8"	55	5	10	14.7	M8	12	8	7.5	M6	ch 10	7	45	52	69
50	16	11	42	M6	69	G1/8"	68	6	12	14.3	M10	16	10	7.5	M8	ch 13	8	45	53	73
63	16	11	50	M6	79	G1/8"	78	6	12	15.8	M10	16	10	7.5	M8	ch 13	8	49	57	77
80	20	15	65	M8	95	G1/8"	94	8	14	16.4	M12	20	12	7.5	M10	ch 17	10	54	64	88
100	24	15	80	M10	115.5	G1/8"	114.5	10	14	17.5	M12	25	12	7.5	M10	ch 22	10	67	77	101

# cilindri compatti ISO 21287

compact cylinders ISO 21287



## DOBPIO EFFETTO, STELO PASSANTE FORATO, FILETTO STELO FEMMINA

double acting, perforated passing-through rod, female rod thread

alesaggio bore	A	B	øD	corsa massima maximum stroke
25	M5	10	2.5	235
32	M5	10	3.5	290
40	M5	10	3.5	290
50	G1/8"	10	5	355
63	G1/8"	10	5	460
80	G1/4"	11	8	450
100	G1/4"	11	10	500

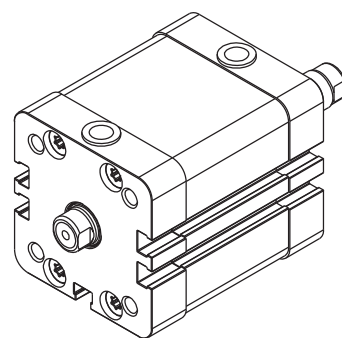
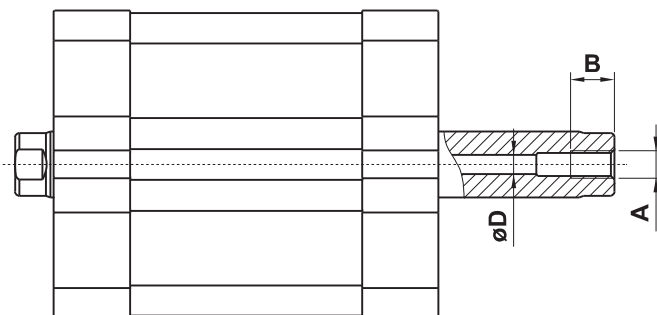

## DOBPIO EFFETTO, STELO PASSANTE FORATO, FILETTO STELO MASCHIO

double acting, perforated passing-through rod, male rod thread

alesaggio bore	A	B	øD	corsa massima maximum stroke
25	M5	10	2.5	220
32	M5	10	3.5	275
40	M5	10	3.5	275
50	G1/8"	10	5	330
63	G1/8"	10	5	430
80	G1/4"	11	8	425
100	G1/4"	11	10	470

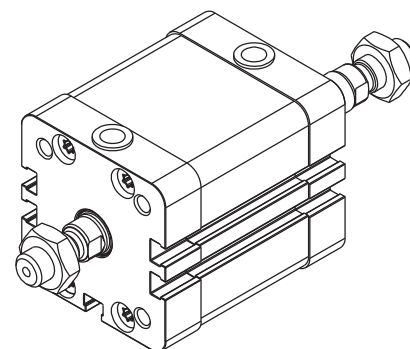
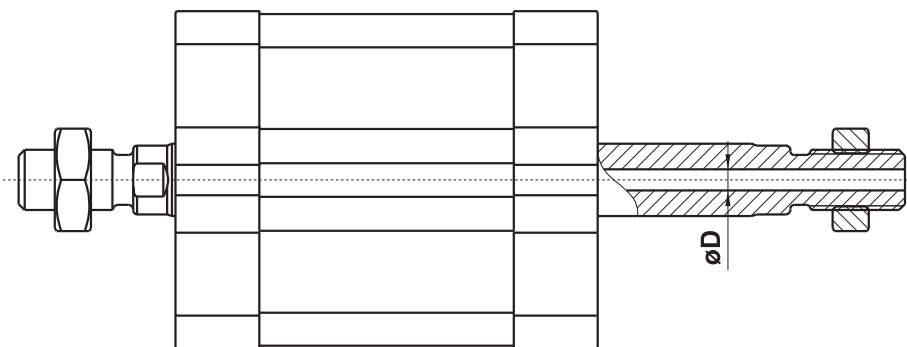



## TANDEM IN SPINTA STELI INDIPENDENTI DUE POSIZIONI

tandem cylinder, independent piston rods, two positions

Esempio di codifica

Example of order code

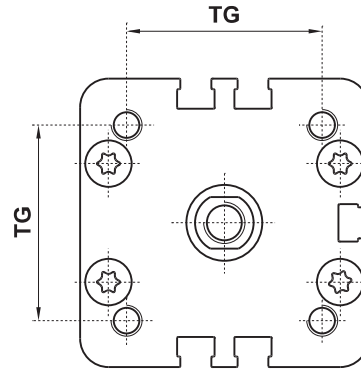
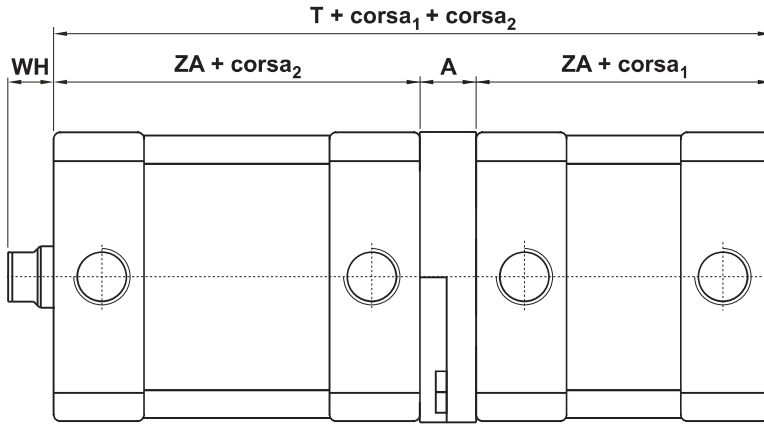

Q11H20320080/0100  
corsa<sub>1</sub> corsa<sub>2</sub>

U11H20320080/0100  
corsa<sub>1</sub> corsa<sub>2</sub>

## TANDEM IN SPINTA STELO COMUNE

tandem cylinder, one piston rod

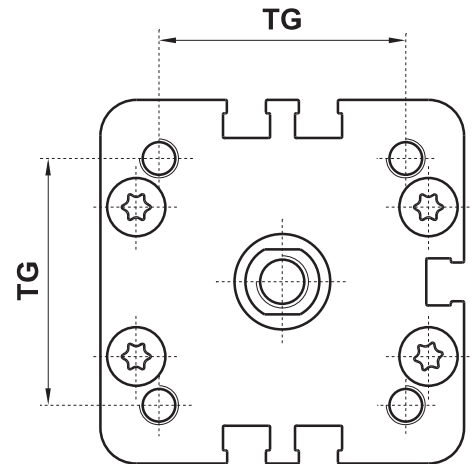
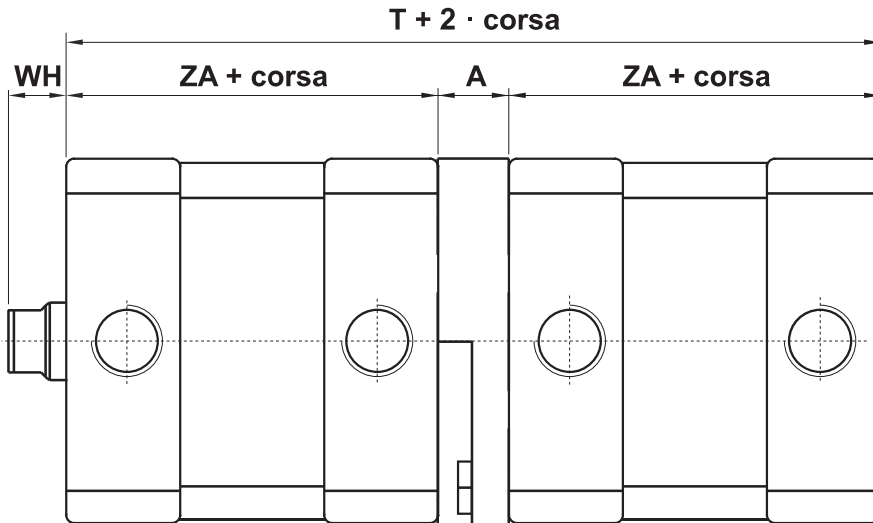

alesaggio bore	A	TG ±0.1		T	WH	ZA
		ISO	UNITOP			
25	10.5	26	-	88.5	6	39
32	10.5	32,5	32,5	98,5	7	44
40	12,5	38	42	102,5	7	45
50	12,5	46,5	50	102,5	8	45
63	13,5	56,5	62	111,5	8	49
80	15	72	82	123	10	54
100	15	89	103	149	10	67

Esempio di codifica

Example of order code

Q11F20320100

U11F20320100

## FLANGIA INTERMEDIA PER CILINDRI COMPATTI CONTRAPPOSTI

intermediate flange for opposite compact cylinders

Questa flangia intermedia deve essere inserita tra due cilindri compatti ISO 21287 per formare un cilindro contrapposto. È venduta in kit con tutti i particolari necessari al suo assemblaggio.

*This intermediate flange is inserted between two compact cylinders ISO 21287 to form an opposite cylinder. It is sold in kit with all necessary pieces for installation.*

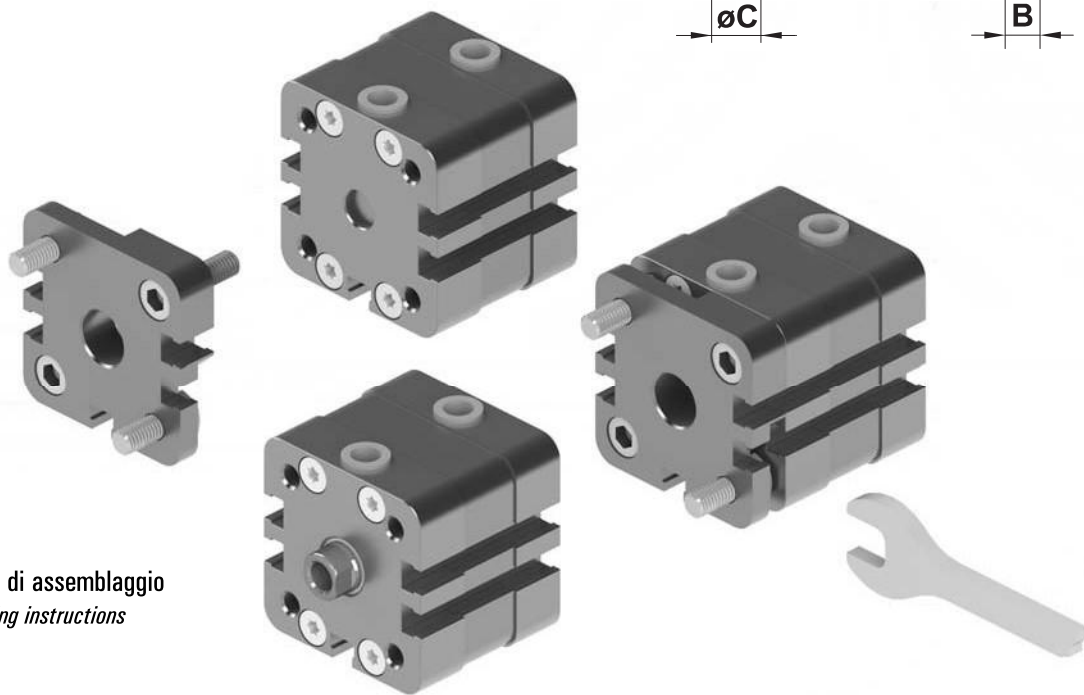
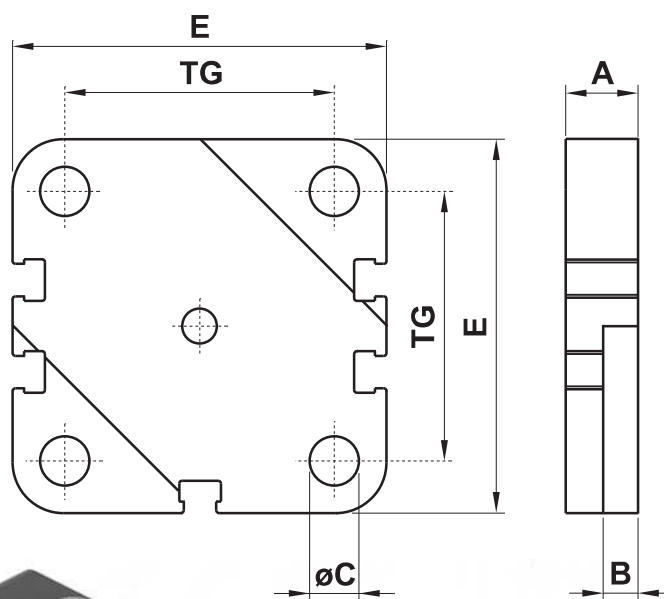

Schema di assemblaggio  
Assembling instructions

codice code		per alesaggio for bore	A	TG ±0.1		B	C	E
ISO	UNITOP			ISO	UNITOP			
39.081.2	-	25	10.5	26	-	5	5.5	42.7
39.082.2	39.082.2	32	10.5	32.5	32.5	5	6.5	49
39.083.2	39.088.2	40	12.5	38	42	6	6.5	56
39.084.2	39.089.2	50	12.5	46.5	50	6	8.5	69
39.085.2	39.090.2	63	13.5	56.5	62	7	8.5	79
39.086.2	39.091.2	80	15	72	82	7	10.5	95
39.087.2	39.092.2	100	15	89	103	7	10.5	115.5

## CILINDRO COMPATTO CONTRAPPOSTO

opposite compact cylinder

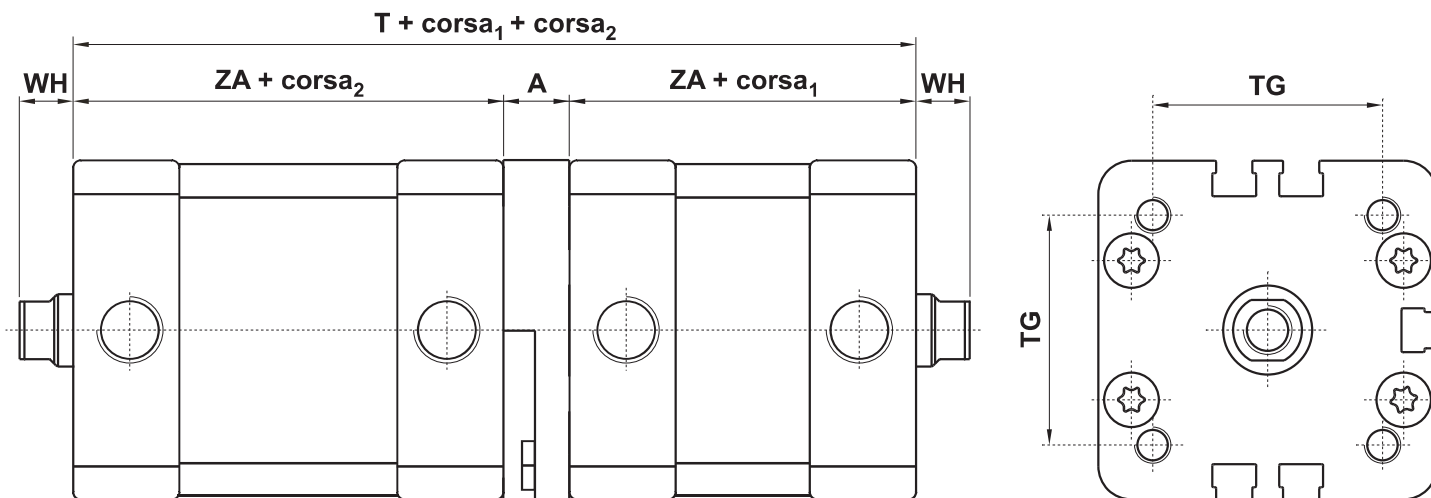

### Contrapposto a 3 posizioni

Opposite cylinder with 3 positions

Per questa configurazione le due parti del cilindro contrapposto devono avere la stessa corsa.

To achieve this configuration two cylinders of identical stroke length must be connected together.

### Contrapposto a 4 posizioni

Opposite cylinder with 4 positions

Per questa configurazione le due parti del cilindro contrapposto devono avere corse differenti.

To achieve this configuration two cylinders of different stroke length must be connected together.

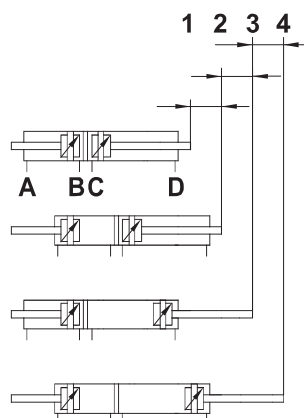
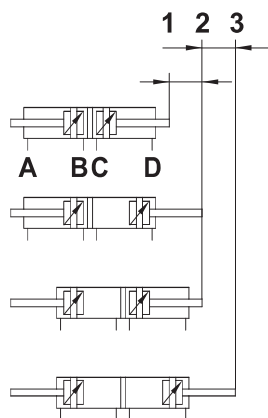

### Esempio di codifica

Example of order code

Q11D20320100/0150  
corsa<sub>1</sub> corsa<sub>2</sub>

U11D20320100/0150  
corsa<sub>1</sub> corsa<sub>2</sub>

alesaggio bore	A	TG ±0.1		T	WH	ZA
		ISO	UNITOP			
25	10.5	26	26	88.5	6	39
32	10.5	32.5	32.5	98.5	7	44
40	12.5	38	42	102.5	7	45
50	12.5	46.5	50	102.5	8	45
63	13.5	56.5	62	111.5	8	49
80	15	72	82	123	10	54
100	15	89	103	149	10	67

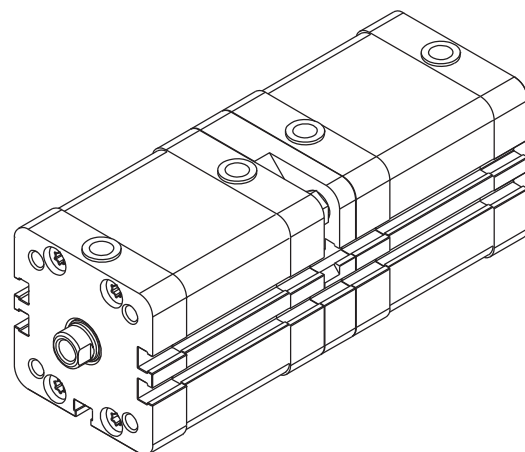

## KIT CILINDRO COMPATTO ISO 21287 E UNITOP

compact cylinder kit for ISO 21287 and UNITOP

### Il kit comprende:

- testate premontate
- pistone in alluminio con magnete, guarnizioni e anello di guida
- viti
- tutte le guarnizioni necessarie

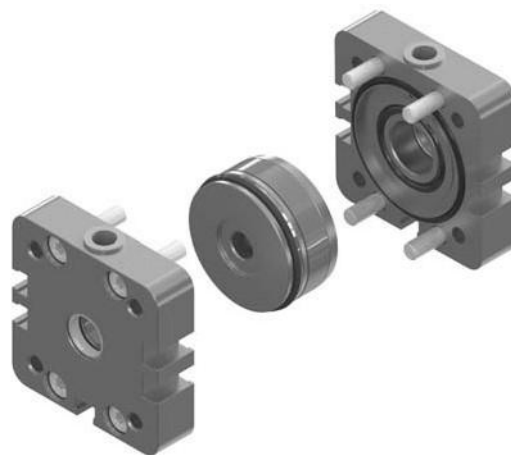

### MAGNETICO, guarnizioni standard

normale		stelo passante [passing-through rod]							
per alesaggio for bore	ISO		UNITOP		per alesaggio for bore	ISO		UNITOP	
	sigla part number	codice code	sigla part number	codice code		sigla part number	codice code	sigla part number	codice code
25	<b>KQ025</b>	39.003.3			25	<b>KQ025P</b>	39.013.3		
32	<b>KQ032</b>	39.004.3	<b>KQ032</b>	39.004.3	32	<b>KQ032P</b>	39.014.3	<b>KQ032P</b>	39.014.3
40	<b>KQ040</b>	39.005.3	<b>KU040</b>	39.105.3	40	<b>KQ040P</b>	39.015.3	<b>KU040P</b>	39.115.3
50	<b>KQ050</b>	39.006.3	<b>KU050</b>	39.106.3	50	<b>KQ050P</b>	39.016.3	<b>KU050P</b>	39.116.3
63	<b>KQ063</b>	39.007.3	<b>KU063</b>	39.107.3	63	<b>KQ063P</b>	39.017.3	<b>KU063P</b>	39.117.3
80	<b>KQ080</b>	39.008.3	<b>KU080</b>	39.108.3	80	<b>KQ080P</b>	39.018.3	<b>KU080P</b>	39.118.3
100	<b>KQ100</b>	39.009.3	<b>KU100</b>	39.109.3	100	<b>KQ100P</b>	39.019.3	<b>KU100P</b>	39.119.3

### MAGNETICO, guarnizioni VITON

normale		stelo passante [passing-through rod]							
per alesaggio for bore	ISO		UNITOP		per alesaggio for bore	ISO		UNITOP	
	sigla part number	codice code	sigla part number	codice code		sigla part number	codice code	sigla part number	codice code
25	<b>KQ025V</b>	39.023.3			25	<b>KQ025PV</b>	39.033.3		
32	<b>KQ032V</b>	39.024.3	<b>KQ032V</b>	39.024.3	32	<b>KQ032PV</b>	39.034.3	<b>KQ032PV</b>	39.034.3
40	<b>KQ040V</b>	39.025.3	<b>KU040V</b>	39.125.3	40	<b>KQ040PV</b>	39.035.3	<b>KU040PV</b>	39.135.3
50	<b>KQ050V</b>	39.026.3	<b>KU050V</b>	39.126.3	50	<b>KQ050PV</b>	39.036.3	<b>KU050PV</b>	39.136.3
63	<b>KQ063V</b>	39.027.3	<b>KU063V</b>	39.127.3	63	<b>KQ063PV</b>	39.037.3	<b>KU063PV</b>	39.137.3
80	<b>KQ080V</b>	39.028.3	<b>KU080V</b>	39.128.3	80	<b>KQ080PV</b>	39.038.3	<b>KU080PV</b>	39.138.3
100	<b>KQ100V</b>	39.029.3	<b>KU100V</b>	39.129.3	100	<b>KQ100PV</b>	39.039.3	<b>KU100PV</b>	39.139.3

Maggiori informazioni sono disponibili all'indirizzo internet <http://www.azpneumatica.srl/azweb/ita/kitcilq.htm>

More information is available at the internet address <http://www.azpneumatica.srl/azweb/ita/kitcilq.htm>

# barre per camicia cilindri compatti

barrel for compact cylinders

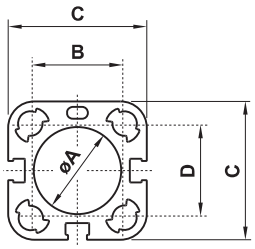
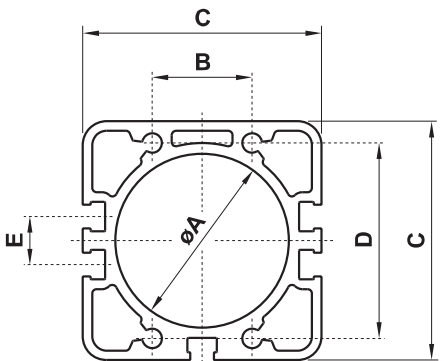
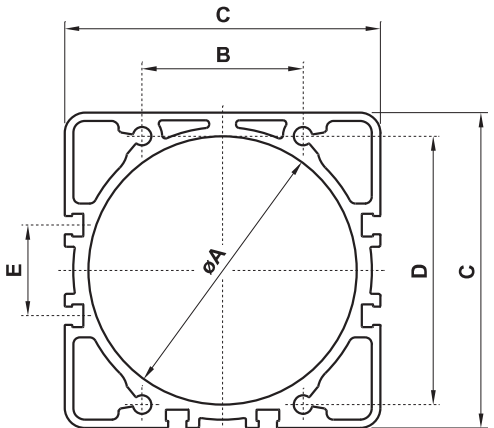

	codice di ordinazione order code	dimensioni - dimensions [mm]					peso weight [kg/m]
		A	B	C	D	E	
	<b>000.552.7</b>	$\varnothing 25^{H11}$	26	39.7	26	-	2.045
	<b>000.553.7</b>	$\varnothing 32^{\pm 0.1}$	18.5	48.2	39	11.05	2.075
	<b>000.554.7</b>	$\varnothing 40^{\pm 0.1}$	23	55	45	11.05	2.52
	<b>000.555.7</b>	$\varnothing 50^{\pm 0.1}$	29	68	55	10	3.384
	<b>000.556.7</b>	$\varnothing 63^{\pm 0.125}$	38	79	65	19	4.155
	<b>000.557.7</b>	$\varnothing 80^{\pm 0.125}$	48	94	80	27	5.371
	<b>000.558.7</b>	$\varnothing 100^{+0.2/-0.1}$	62	114.5	99	40	7.641

composizione chimica chemical composition	Cu	Fe	Mn	Mg	Si	Zn	Cr	Ti	Al resto
	≤ 0.10	0.10 ÷ 0.30	≤ 0.10	0.35 ÷ 0.60	0.30 ÷ 0.60	≤ 0.15	≤ 0.05	≤ 0.10	

## Fori di fissaggio

dal  $\varnothing 25$  al  $\varnothing 100$  : predisposti per l'uso di viti autofilettanti

## Fixing holes

from  $\varnothing 25$  to  $\varnothing 100$  : prepared for the use of self-tapping screws

# fissaggi per cilindri compatti ISO 21287

fixing elements for ISO 21287 compact cylinders



Per altre informazioni vedi le pagine 538-544 (fissaggi per cilindri ISO 15552)

For more information refer to pages 538-544 (fixing elements for cylinders ISO 15552)

## CERNIERA MASCHIO SNODO SFERICO (ø32 ... ø100)

CMSS...

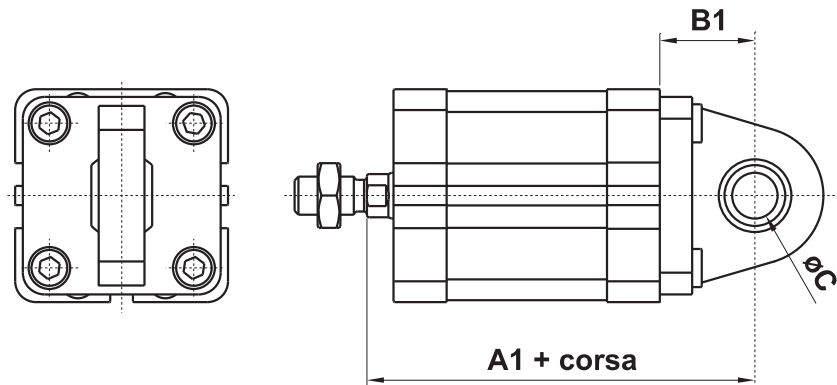

## CERNIERA MASCHIO (ø25 ... ø100)

CMIS...  
CMKS...

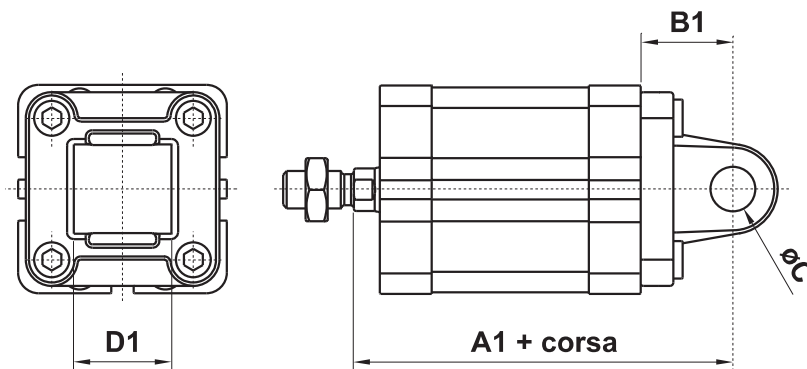

## CERNIERA FEMMINA CON PERNO (ø32 ... ø100)

CFIS...  
CFKS...

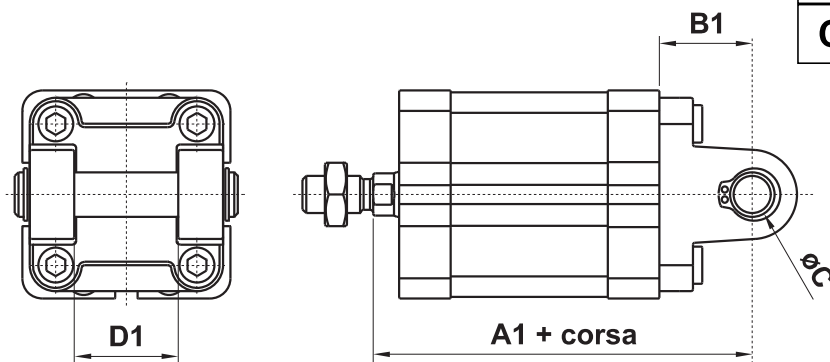

ø	A1	B1	C	D1
25	65	20	8	16
32	73	22	10	26
40	77	25	12	28
50	80	27	12	32
63	89	32	16	40
80	100	36	16	50
100	118	41	20	60

# fissaggi per cilindri compatti ISO 21287

fixing elements for ISO 21287 compact cylinders



Per altre informazioni vedi le pagine 538-544 (fissaggi per cilindri ISO 15552)

For more information refer to pages 538-544 (fixing elements for cylinders ISO 15552)

## FLANGIA

FLIS...

disegno per alesaggio 32-100  
drawing for bore 32-100

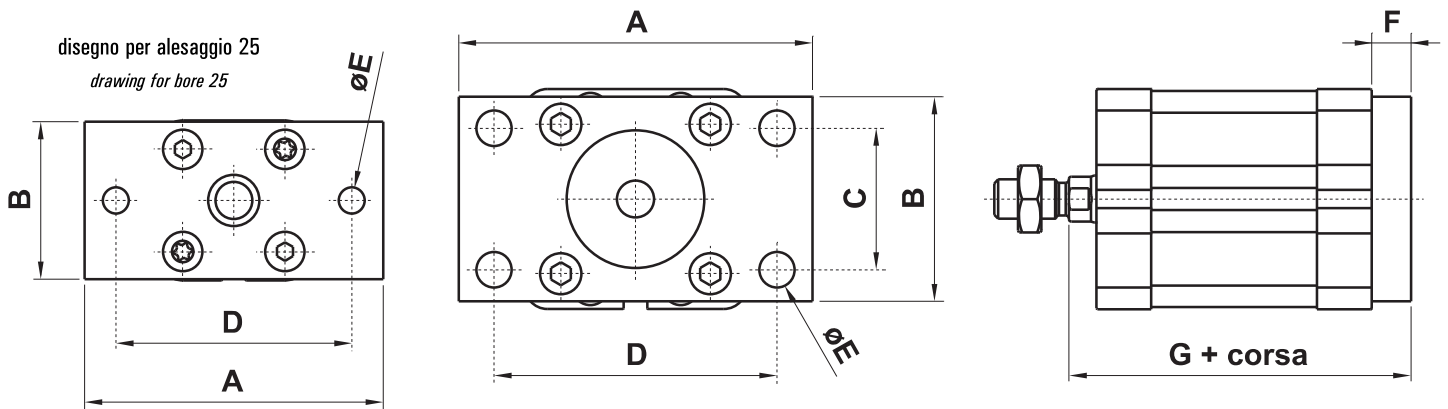

## PIEDINO

PBIS...

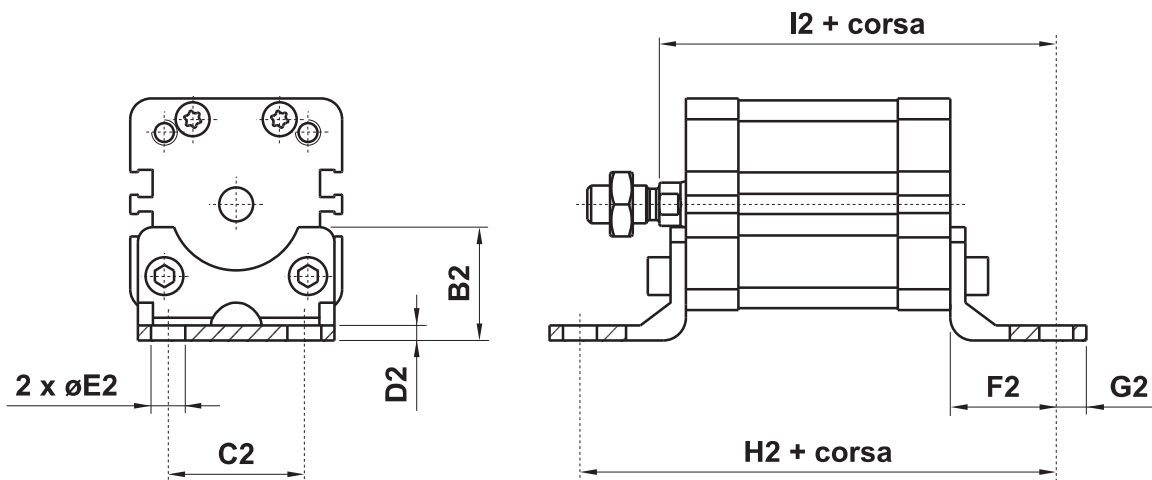

G	F	E	D	C	B	A	ø	B2	C2	D2	E2	F2	G2	H2	I2
55	10	6.6	60	-	40	76	25	23	26	4	6.6	17	6	73	62
61	10	7	64	32	45	80	32	30	32	4	7	24	11	92	75
62	10	9	72	36	52	90	40	30	36	4	9	28	8	101	80
65	12	9	90	45	65	110	50	36	45	5	9	32	15	109	85
69	12	9	100	50	75	120	63	35	50	5	9	32	13	113	89
80	16	12	126	63	95	150	80	47	63	5	12	41	14	136	105
93	16	14	150	75	115	170	100	53	75	8	14	41	16	149	118



## SCHEMA PER LA SCELTA DEGLI ACCESSORI ISO 21287

scheme for the choice of accessories ISO 21287

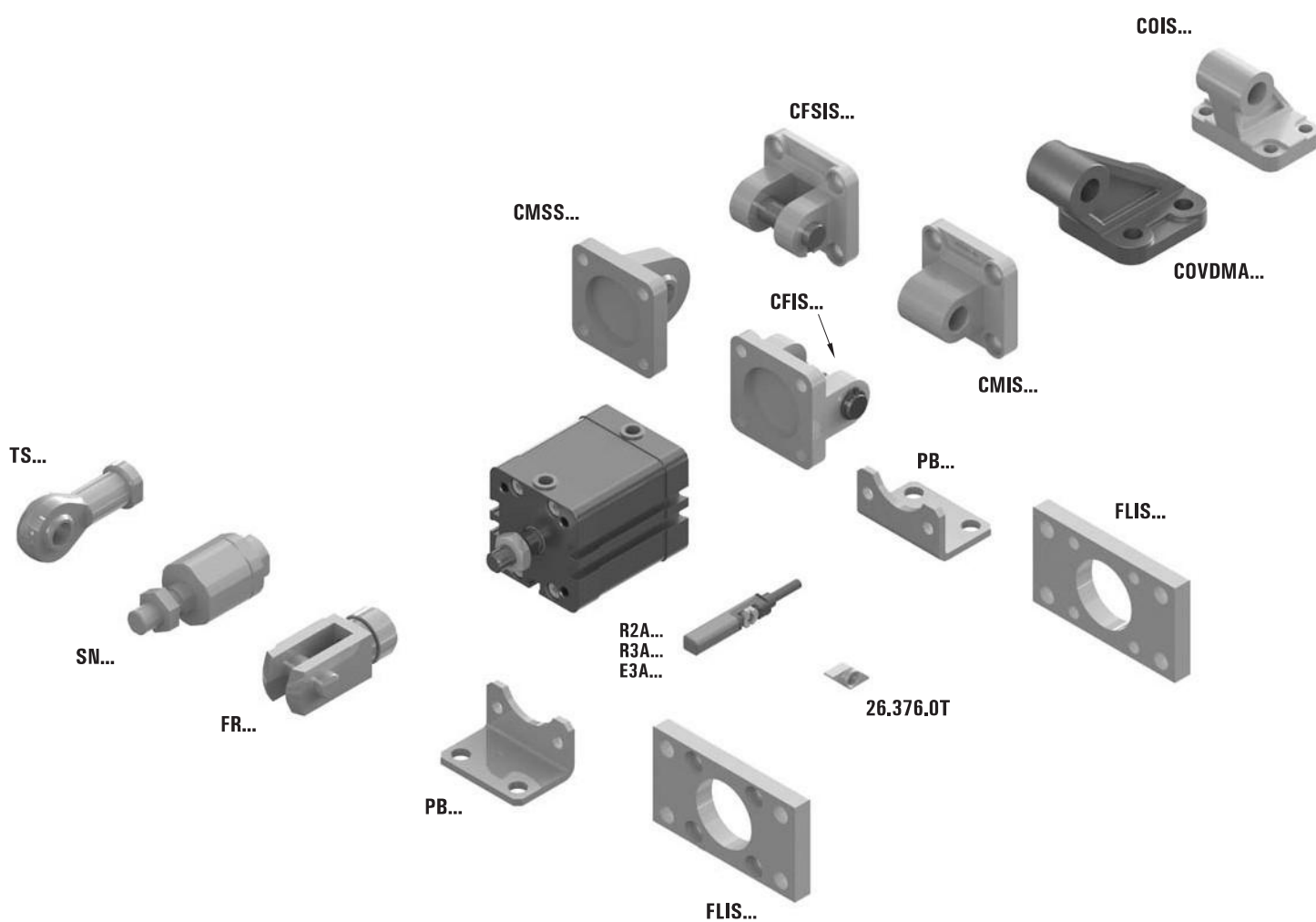

6



## CERNIERA FEMMINA CON PERNO (female hinge with pin)

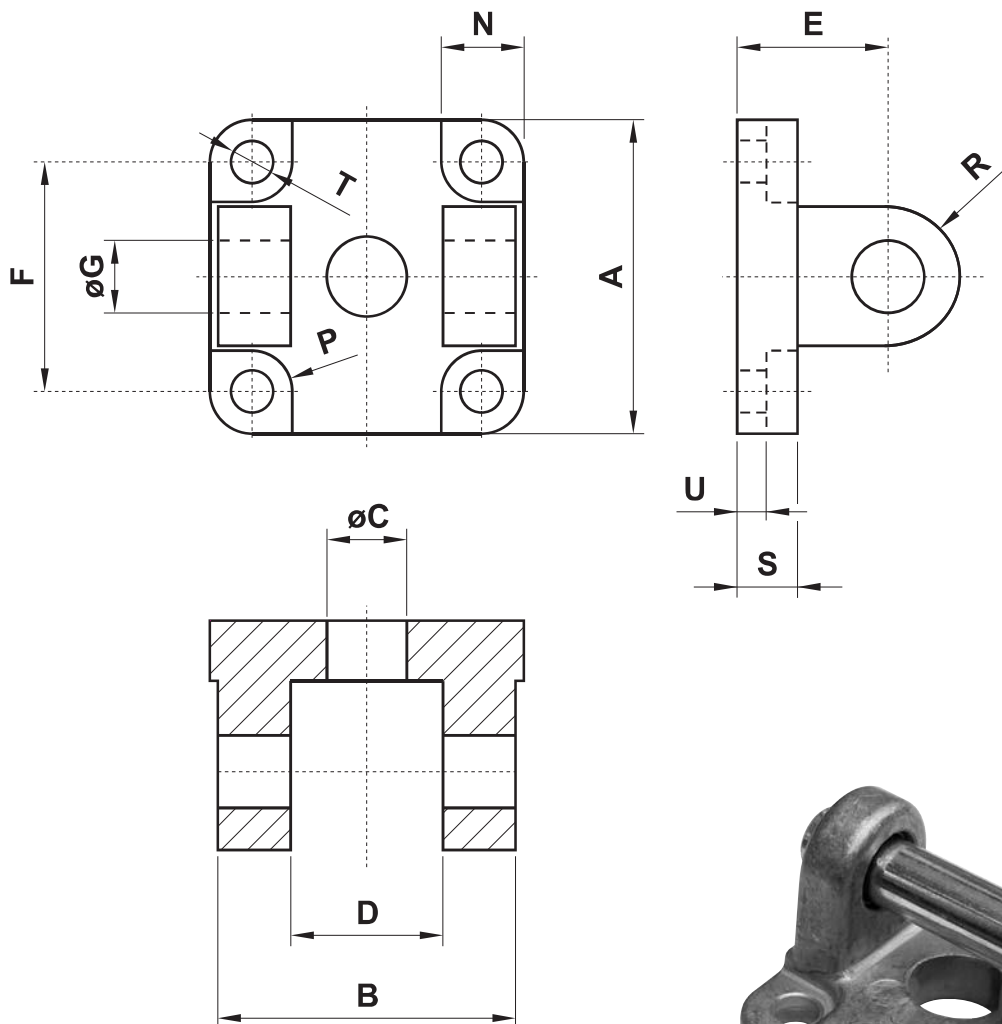

6

sigla part number	sigla part number	per alesaggio for bore	A	B	C	D	E	F	G	N	P	R	S	T	U
standard	con boccia di bronzo														
<b>CFUN032</b>	<b>CFKN032</b>	32	48	45	14	26	22	32	10	13.5	5.5	10	9	6.6	5.5
<b>CFUN040</b>	<b>CFKN040</b>	40	58	52	14	28	25	42	12	13.5	5.5	12.5	9	6.6	5.5
<b>CFUN050</b>	<b>CFKN050</b>	50	66	60	18	32	27	50	12	15.5	7.5	12.5	11	9	6.5
<b>CFUN063</b>	<b>CFKN063</b>	63	83	70	18	40	32	62	16	18	7.5	15	11	11	6.5
<b>CFUN080</b>	<b>CFKN080</b>	80	102	90	23	50	36	82	16	19	9	15	13	11	10
<b>CFUN100</b>	<b>CFKN100</b>	100	123	110	28	60	41	103	20	19	9	20	15	11	10

## FLANGIA (flange)

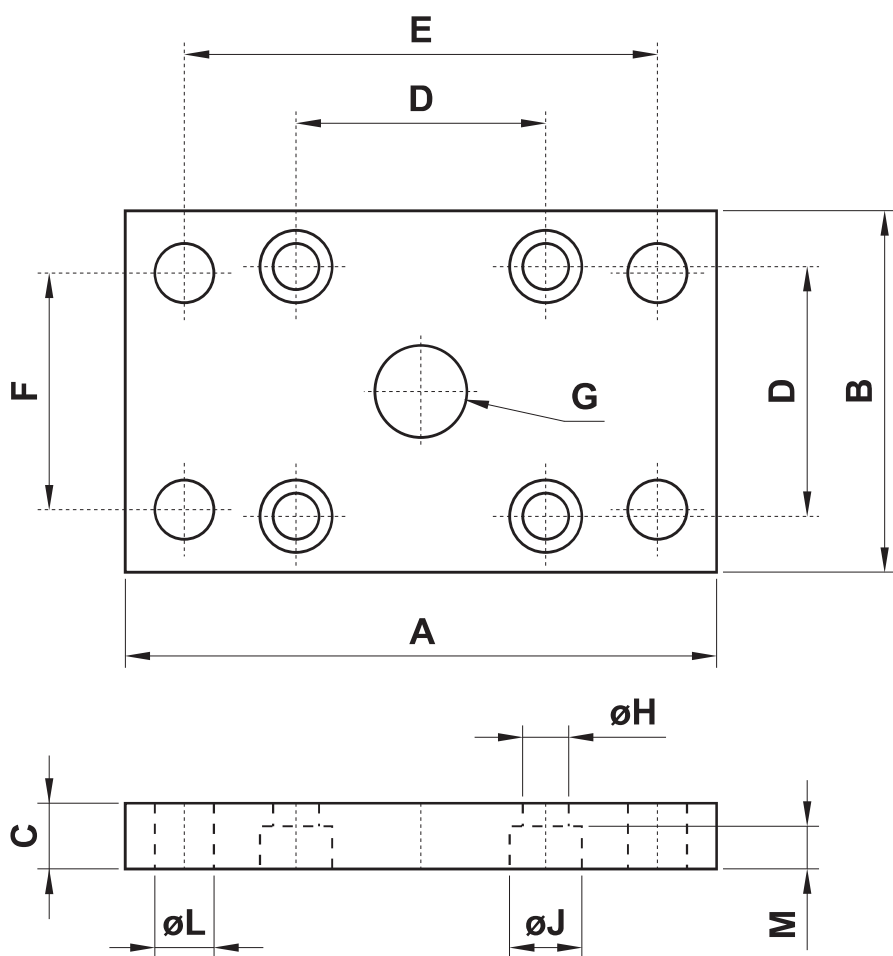
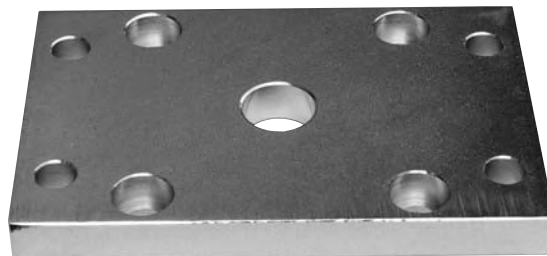

sigla part number	per alesaggio for bore	A	B	C	D	E	F	G	H	J	L	M
<b>FLUN032</b>	32	80	50	10	32	65	32	ø14	6.6	11	7	6.4
<b>FLUN040</b>	40	102	60	10	42	82	36	ø14	6.6	11	9	6.4
<b>FLUN050</b>	50	110	68	12	50	90	45	ø18	9	15	9	8.6
<b>FLUN063</b>	63	130	87	15	62	110	50	ø18	11	15	9	8.6
<b>FLUN080</b>	80	160	107	15	82	135	63	ø23	11	18	12	10.6
<b>FLUN100</b>	100	190	128	15	103	163	75	ø28	11	18	14	10.6

## PIEDINO (foot mounting)

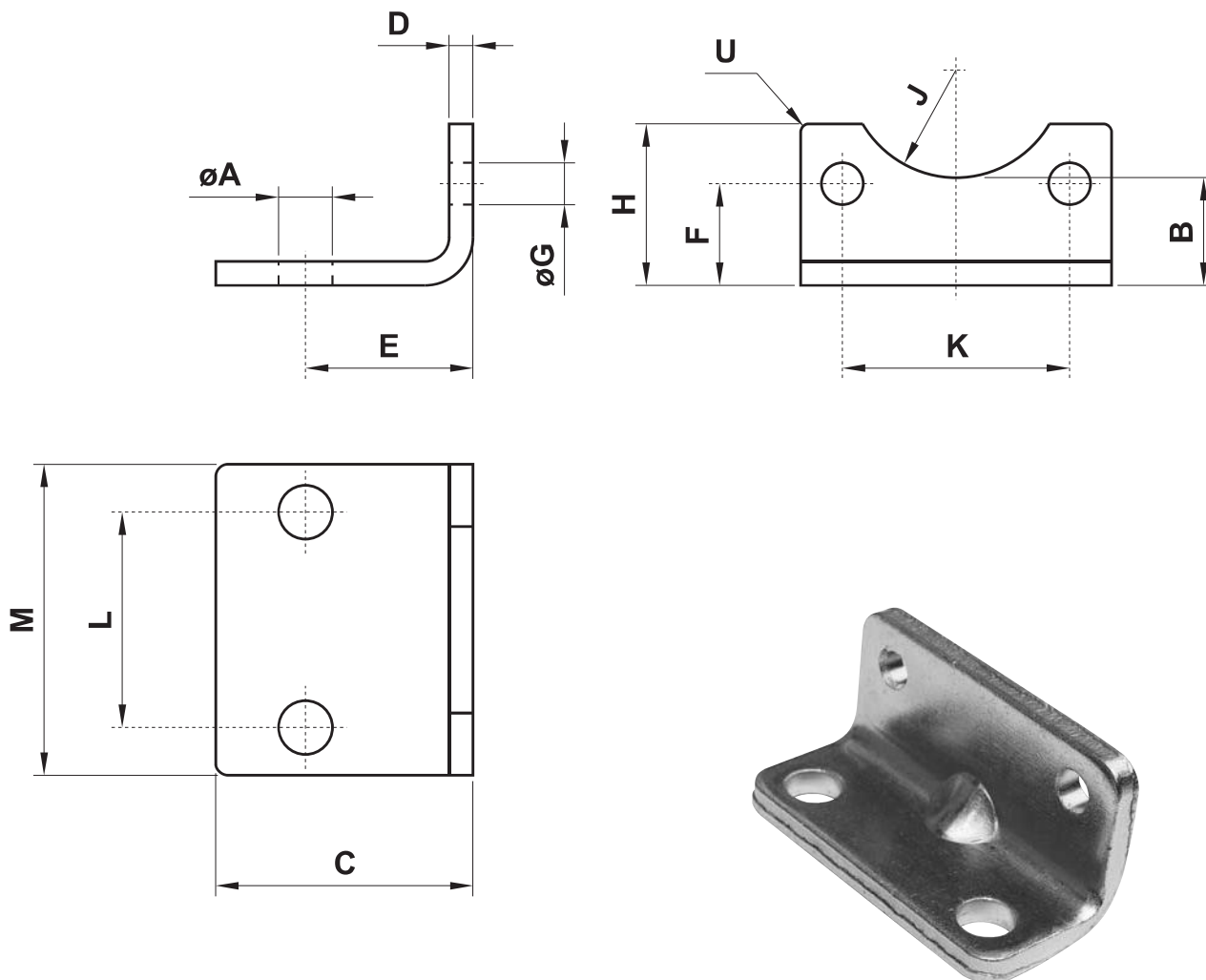

sigla* part number*	per alesaggio for bore	A	B	C	D	E	F	G	H	J	K	L	M	U
<b>PBUN025</b>	25	6.6	19	22	4	16	17	5.4	23	11	26	26	40	2
<b>PBUN032</b>	32	6.6	20	26	5	18	16	6.6	24	12	32	32	50	2
<b>PBUN040</b>	40	9	-	28	5	20	21.5	6.6	29.5	-	42	42	60	5
<b>PBUN050</b>	50	9	-	32	6	24	22	9	30	-	50	50	68	5
<b>PBUN063</b>	63	11	-	39	6	27	28.5	9	39	-	62	62	84	5
<b>PBUN080</b>	80	11	-	42	8	30	24.5	11	36.5	-	82	82	102	5
<b>PBUN100</b>	100	13.5	-	45	8	33	26.5	11	38.5	-	103	103	123	5

\* La sigla si riferisce a un solo piedino e non alla coppia

\* The part number is referred to only one element and not to the couple