

SERIE GR05F - PINZE PNEUMATICHE 3 GRIFFE

PNEUMATIC 3 FINGERS GRIPPER
 PNEUMATISCHER GREIFER MIT 3 BACKEN
 PINCE PNEUMATIQUE A 3 DOIGTS
 PINZA NEUMÁTICA DE 3 DEDOS
 GARRA PNEUMÁTICA DE 3 DEDOS



CARATTERISTICHE TECNICHE
 TECHNICAL CHARACTERISTICS
 TECHNISCHE ANGABEN
 CARACTÉRISTIQUES TECHNIQUES
 CARACTERÍSTICAS TÉCNICAS
 CARACTERÍSTICAS TÉCNICAS



1907/2006
 REACH ✓
 2011/65/CE
 RoHS ✓

SILICON
 FREE

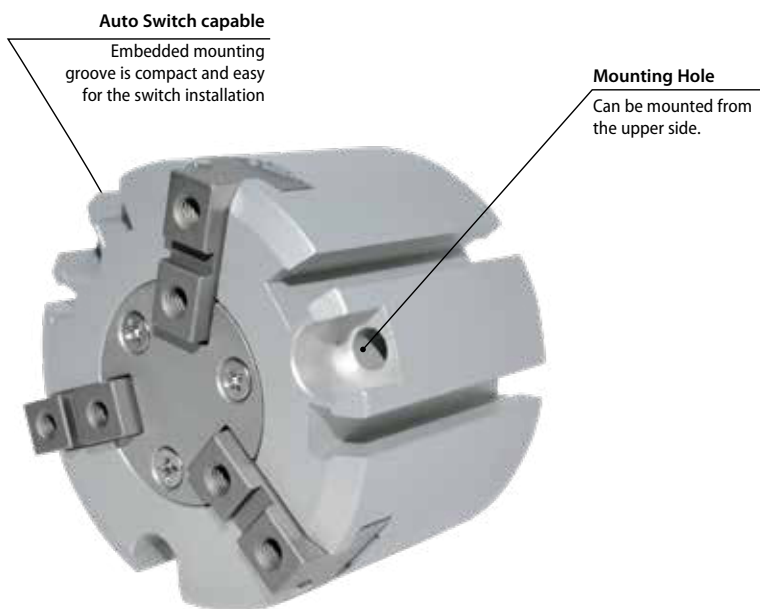

| Materiali | IT | Materials | GB | Materialien | DE |
|---|----|---|----|--|----|
| <ul style="list-style-type: none"> Corpo: Lega Alluminio Stelo: Acciaio Guarnizioni: NBR | | <ul style="list-style-type: none"> Body: Aluminum alloy Piston rod: Steel NBR seal | | <ul style="list-style-type: none"> Körper: Aluminiumlegierung Kolbenstange: Stahl Dichtung: NBR | |
| Matériaux | FR | Materiales | ES | Materiais | PT |
| <ul style="list-style-type: none"> Corps: Alliage d'aluminium Tige : Acier Joints: NBR | | <ul style="list-style-type: none"> Cuerpo: Aleación de aluminio Eje: Acero Juntas: NBR | | <ul style="list-style-type: none"> Corpo : Liga de alumínio Haste : Aço Vedações : NBR | |



Pressioni
 Pressures
 Druckbereich
 Pressions
 Presiones
 Pressões

∅ 25 **∅ 32 ÷ 63**
2 bar (0.2 MPa) **1 bar** (0.1 MPa)
6 bar (0.6 MPa) **6 bar** (0.6 MPa)



Temperature
 Temperatures
 Temperatur
 Températures
 Temperaturas
 Temperaturas

-10 °C
+ 60 °C



Fluidi compatibili
 Aria (Lubrificazione non necessaria).
 Fluids
 Air (Lubrication not necessary).
 Geeignete Medien
 Luft (Schmierung nicht erforderlich).
 Fluides compatibles
 Air (Lubrification pas nécessaire).
 Fluidos compatibles
 Aire (Lubrificación no necesaria).
 Fluidos compatíveis
 Ar (Lubrificação não necessária).



Alesaggi
 Bores
 Durchmesser
 Diamètres
 Diámetros
 Diâmetros

25-32-40-50-63 mm



Ripetibilità
 Action tolerance
 Wiederholgenauigkeit
 Répétitivité
 Repetibilidad
 Repetibilidade

± 0,01 mm



Frequenza massima d'esercizio
 Max. Operating frequency
 Maximale Betriebsfrequenz
 Fréquence d'utilisation maximum
 Frecuencia máxima de ejercicio
 Frequência máxima de trabalho

120 c.p.m. (∅ 25)
60 c.p.m. (∅ 32 ÷ 63)



Peso della pinza

Gripper Weight

Gewicht Greifer

Poids de la pince

Peso de la pinza

Peso da garra

| Ø | | | | |
|-----|-----|-----|-----|-----|
| 25 | 32 | 40 | 50 | 63 |
| 140 | 237 | 351 | 541 | 992 |

(Unit: g)



Corsa totale di apertura/chiusura

Opening/Closing stroke

Oeffnungs/Schliesshub

Course d'ouverture/fermeture

Carrera de apertura/cierre

Curso de abertura/fechamento

| Ø | | | | |
|----|----|----|----|----|
| 25 | 32 | 40 | 50 | 63 |
| 6 | 8 | 8 | 12 | 16 |

(Unit: mm)



Momento di presa a 5 bar

Holding Moment at 5 bar

Greifmoment bei 5 bar

Moment de préhension à 5 bar

Momento de agarre a 5 bar

Momento de pega a 5 bar

| Ø | | | | |
|------|----|-----|-----|-----|
| 25 | 32 | 40 | 50 | 63 |
| E 42 | 74 | 118 | 187 | 335 |
| I 47 | 82 | 130 | 204 | 359 |

(Unit: N)



Punto di presa

Holding point

Greifmoment

Moment de préhension

Punto de agarre

Ponto de pega



Forza effettiva di presa a 5 bar

Effective gripping force at 5 bar

Effektive Greifkraft bei 5 bar

Force de préhension effective à 5 bar

Fuerza efectiva de agarre 5 bar

Força efetiva de agarre a 5 bar

E

External grip

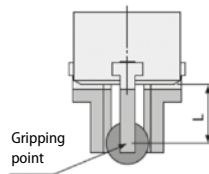

GR05F 025

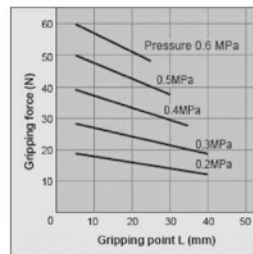

GR05F 032

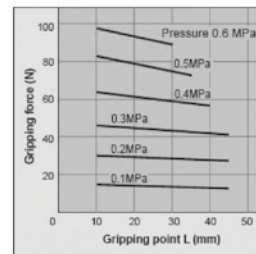

GR05F 040

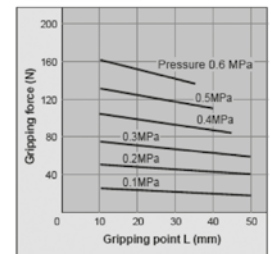

GR05F 050

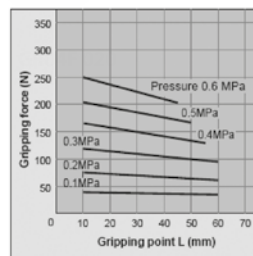

GR05F 063

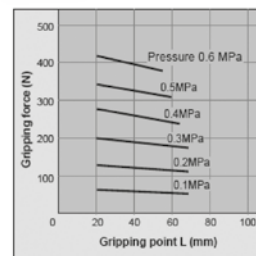

I

Internal grip

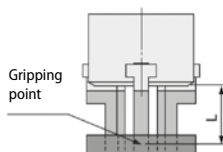

GR05F 025

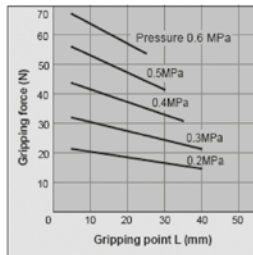

GR05F 032

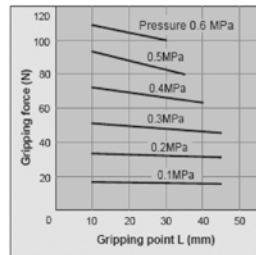

GR05F 040

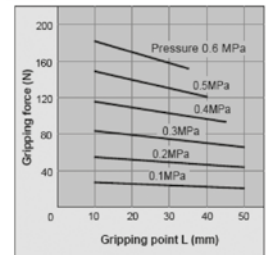

GR05F 050

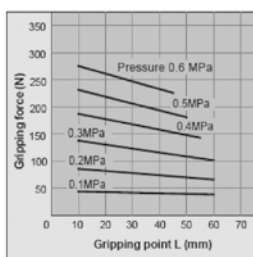

GR05F 063





Tabella dei codici di ordinazione

- Ordering codes
- Bestellschlüssel
- Code de commande
- Tabla de codificación para pedidos
- Tabela de codificação para compra

| SERIE | Ø mm |
|-------|---------|
|-------|---------|

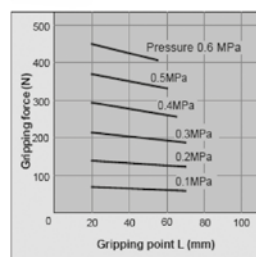
G R 0 5 F **0 2 5**

- | | |
|--------------------------|-----|
| Doppio Effetto Magnetico | 025 |
| Double Acting Magnetic | 032 |
| Doppelwirkend Magnetisch | 040 |
| Double Effet Magnétique | 050 |
| Doble efecto magnético | 063 |
| Dupla Ação Magnético | |



Sensori consigliati

- Sensors recommended
- Empfohlene Sensoren
- Capteurs recommandés
- Sensores recomendados
- Sensores aconselhados

DC 03 PM8 DC 04 PM8
DC 03 P2M DC 04 P2M



Adattatore Per Sensore

- Sensor Adapter
- Sensor Adapter
- Adaptateur Pour Capteur
- Adaptador Para Sensor
- Adaptador Para Sensor

DC 10 001

GR05F 025

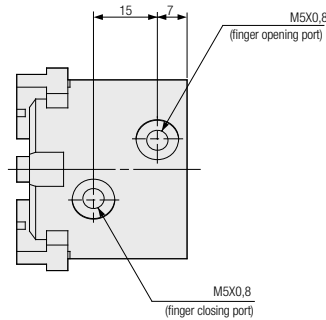
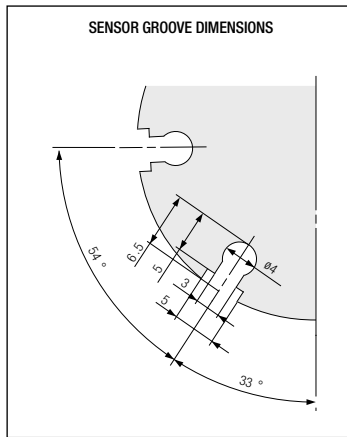
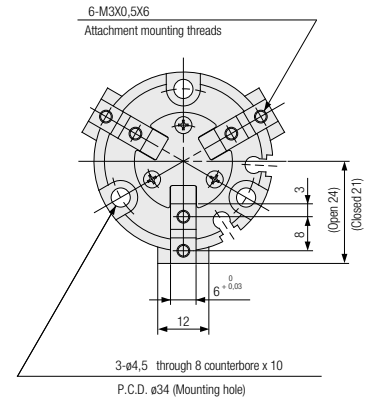
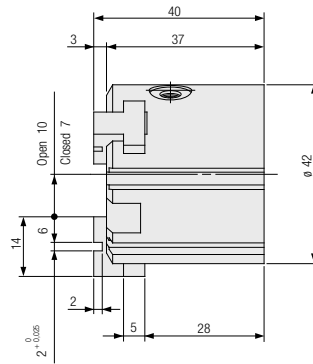
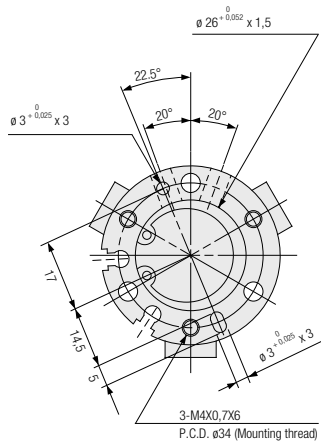

GR05F 032

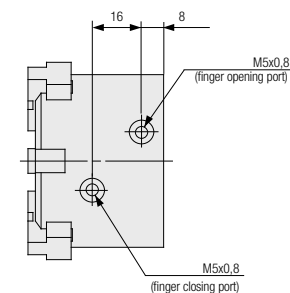
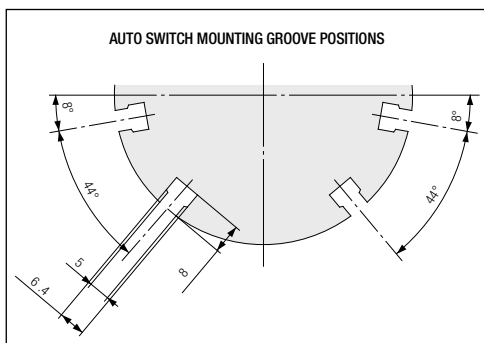
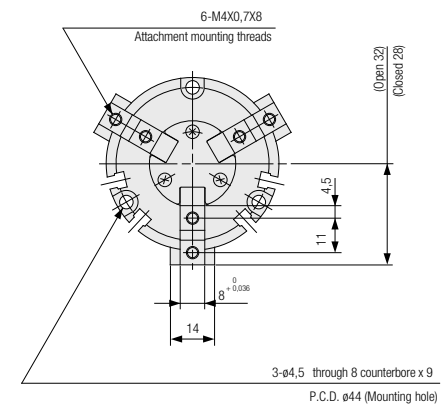
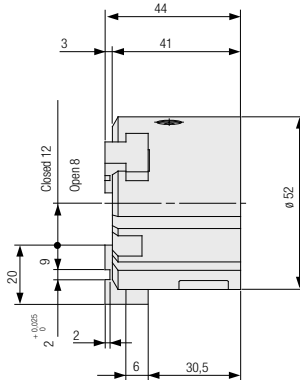
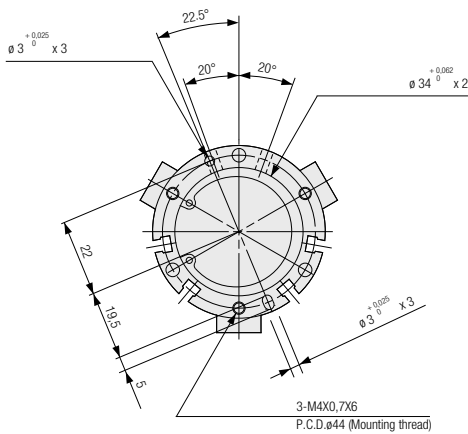

GR05F 040

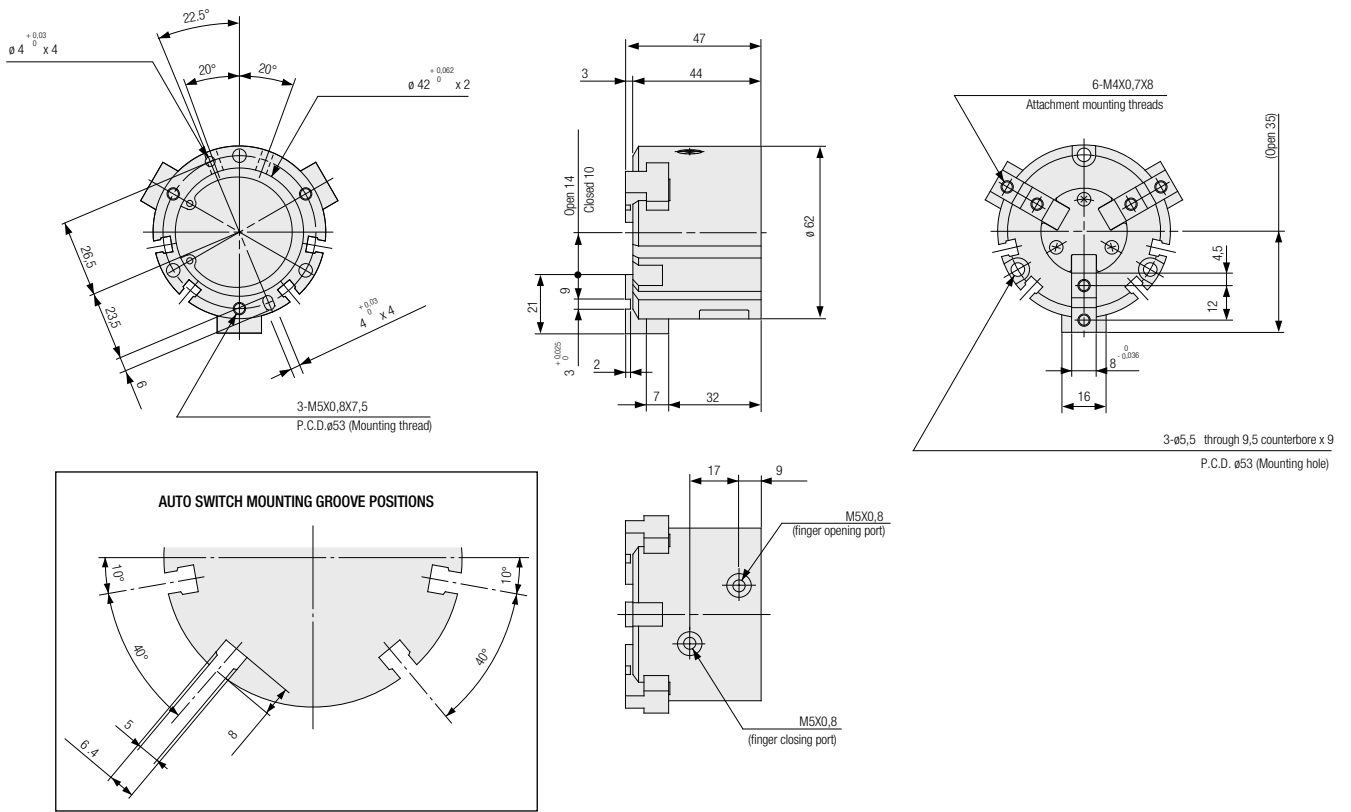

GR05F 050

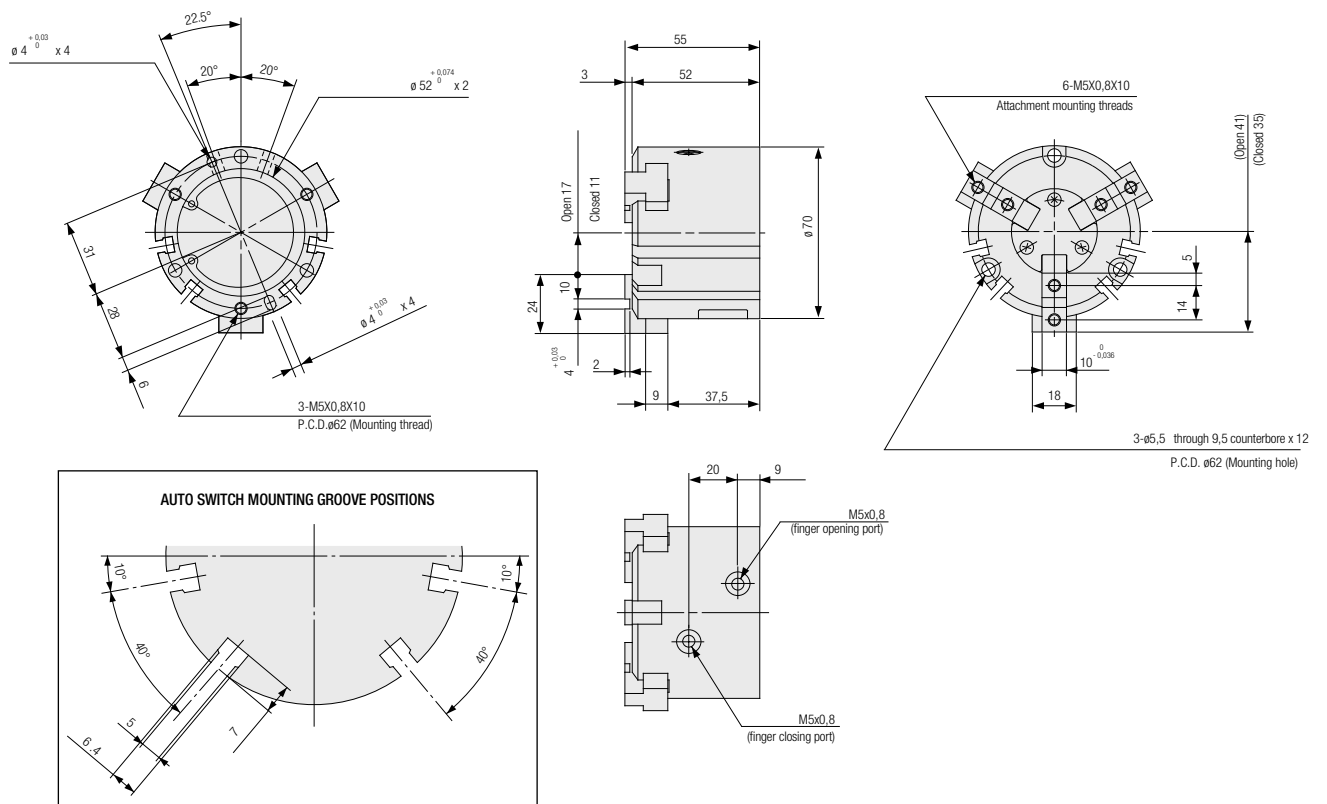

GR05F 063

