

# Data sheet

---

## pressure booster (4 : 1), G 1/4", to 60 l/min

**Item number:**

DUE 60 A



Example illustration

### Item description

**Application:**

The pressure booster increases the input pressure to the value set on the control valve. The outlet pressure can measure max. four or two times the input pressure, but can never exceed the max. outlet pressure. Should an individual consumer (clamping cylinder etc.) be operated with a pressure higher than the standard network pressure, the pressure booster can accordingly increase the supply pressure for this single consumer. An installed pressure regulator maintains a constant working pressure (with less pulsation).

**Advantages:**

High energy saving and no electrical energy necessary directly on consumer. For a further consumer, it is not necessary to pretension the entire compressed air network to a higher level.

**Installation recommendation:**

In order to reduce the pressure pulsation on the secondary side, we recommend creating an additional volume in the form of a container. If the volume of the serially connected air duct is insufficient, we recommend the container volumes given in the table.

**Media:**

Filtered, unoiled compressed air

**Installation position:**

horizontal

**Temperature range:**

+5°C to +50°C

**Warning:**

Order accessories at the same time! Please order silencers and pressure gauges separately!

### Properties

<b>Gear ration max.</b>	4 : 1
<b>Outlet pressure [bar]</b>	2 - 20

Flow capacity* [l/min]	60
Connection thread	G 1/4"
Pressure gauge connection	R 1/8"
Recommended container volume [LTR]	1.3 - 3
Accessories pressure gauges	MW 2527

### Further information:

Weight	900 g / Pcs
GTIN	4050571276904
Customs duty number	84148028

### Drawing:

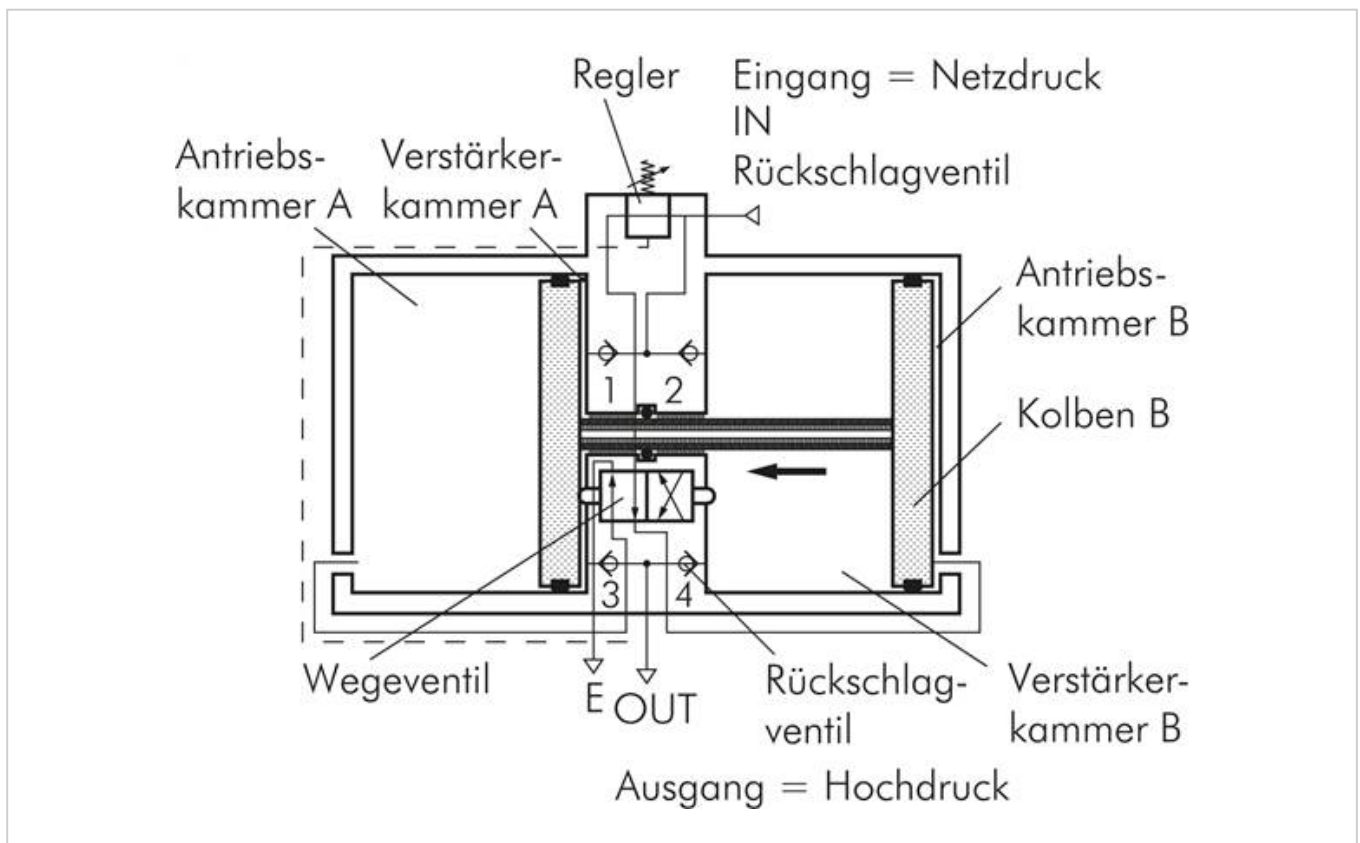

Drawing: Pressure booster