

Serie Medium

435MU

R00000 435MIdM0 S0000

Nylon Cable Chain with opening frames

Inner height (D) 35 mm

Sideband & Frame construction with large anti-friction single-pin. Frames opening from inner radius (435MI) or from outer radius (435ME). Vertical separators are available. This standard 35 mm chain offers very high load capacities, despite its compact construction.

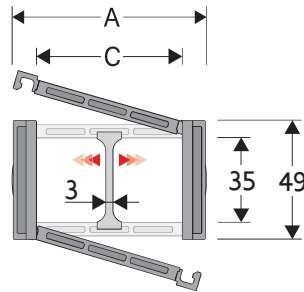

Separator

- Unassembled	Part.no S4353
- Assembled*	Part.no S4353MCI
- Assembled**	Part.no S4353MCE

Pin

Part.no PG4353

* for chain opening outer radius
** for chain opening inner radius

Technical characteristics when self-supported

Speed	10 m/s
Acceleration	50 m/s ²

For higher requirements please consult our technical dept.

A	B	C	D	R	Weight/m	Chain
mm	mm	mm	mm	mm	kg	Part Number
60	49	40	35	060-075-100-125-150-200	1,10	435MU040 □□□ *
70	49	50	35	060-075-100-125-150-200	1,15	435MU050 □□□ *
80	49	60	35	060-075-100-125-150-200	1,20	435MU060 □□□ *
96	49	76	35	060-075-100-125-150-200	1,30	435MU076 □□□ *
117	49	97	35	060-075-100-125-150-200	1,35	435MU097 □□□ *
123	49	103	35	060-075-100-125-150-200	1,45	435MU103 □□□ *
145	49	125	35	060-075-100-125-150-200	1,55	435MU125 □□□ *
170	49	150	35	060-075-100-125-150-200	1,70	435MU150 □□□ *

*Complete the code by inserting the value of the radius (R): Ex. 435MU040 □□□ □

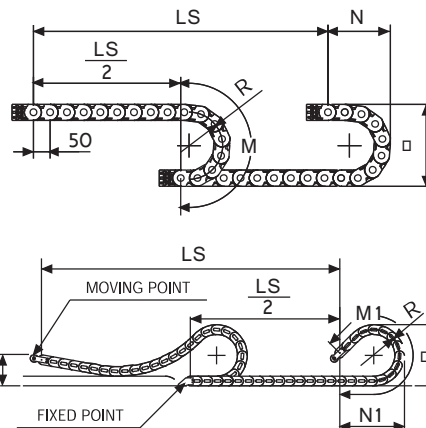

R	H	N	M	N1	M1
mm	mm	mm	mm	mm	mm
060	169	135	290	165	345
075	199	155	340	190	420
100	249	175	415	230	530
125	299	200	495	320	750
150	349	230	575	405	970
200	449	275	730	580	1405

For sliding applications, technical data can slightly change according to frequency, added weight and environment.

SLIDING VERSION
to be ordered with pivoting end brackets set

Length of chain (L)
Half travel distance ($\frac{LS}{2}$)
plus length of curve (M) or (M1)

$$L = \frac{LS}{2} + M \text{ or } M1$$

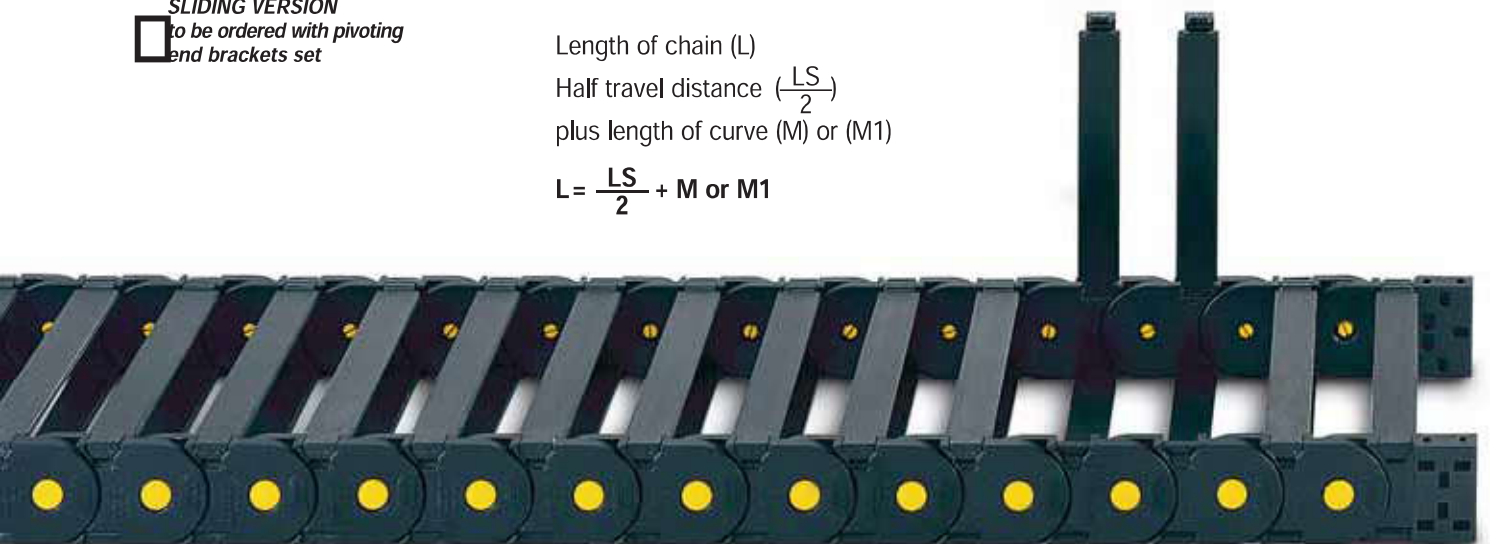

**NEW
CHAIN**

Serie Medium

435MU
Nylon Cable Chain
with opening frames

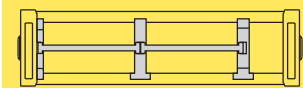

Separation System
To choose the separators see page 199

Bright Zinc Plated Steel Type***

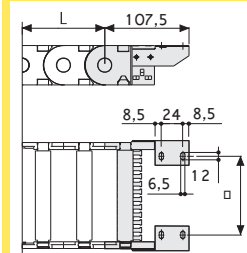
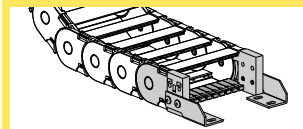

F = A-30

Bright Zinc Plated Steel Type Part Numbers

Complete Set Assembled
A435M □□□ *KM □ **

Complete Set Unassembled
A435M □□□ *K □ **

Tiewrap Clamp Part Numbers

Complete Set Assembled
CFC435M □□□ *KM

Complete Set Unassembled
CFC435M □□□ *K

* Inner width (C)

** 1=Pos.1; 2=Pos.2; 3=Pos.3

*** Available on request in stainless steel

3

Self-Supporting Capacity Diagram

The maximum length of the self-supporting capacity ($\frac{LS}{2}$) in relationship to the weight of the cables and hoses contained per linear metre.

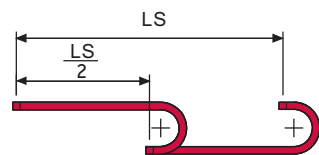
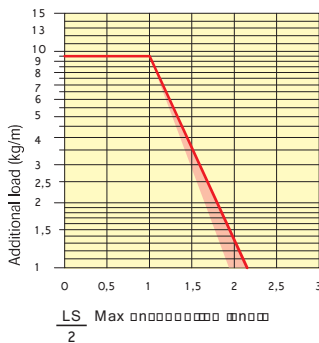

The red marking in the diagram area considers the difference of weight between various widths of chain.

For applications with $\frac{LS}{2}$ and weights not included in the area of the diagram showing self-supporting capacity, verify the possible use of support rollers (see page 30).

End Brackets

The end brackets set allows the two ends of the chain to be attached to the equipment. Set complete with tiewrap clamps available on request.

Nylon Type

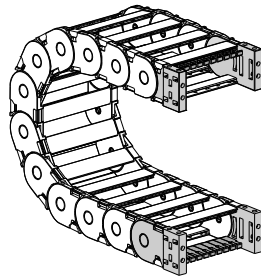
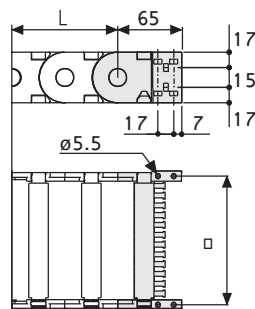

Fig. A
The chain can be fixed frontally, inner or outer radius. (Fig A)



Chain Type	F mm
435MU040	51
435MU050	61
435MU060	71
435MU076	87
435MU097	108
435MU103	114
435MU125	136
435MU150	161

Nylon Type Part Numbers

Complete Set Assembled
AN435M □□□ *KM

Complete Set Unassembled
AN435M □□□ *K

Tiewrap Clamp Part Numbers

Complete Set Assembled
CFC435M □□□ *KM

Complete Set Unassembled
CFC435M □□□ *K

Nylon Type

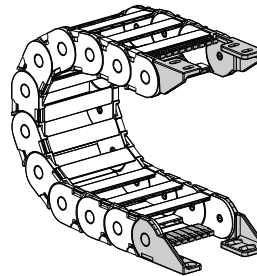
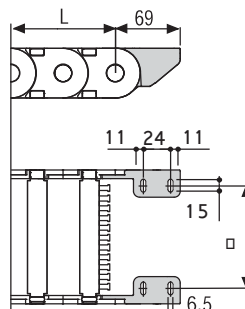

Fig. B
Chain fixed outside the radius. (Fig B)
See end brackets mounting variations page 31.



Chain Type	F mm
435MU040	26,5
435MU050	36,5
435MU060	46,5
435MU076	62,5
435MU097	83,5
435MU103	89,5
435MU125	111,5
435MU150	136,5

Nylon Type Part Numbers

Complete Set Assembled
AN435KM □ ****

Complete Set Unassembled
AN435K □ ****

Tiewrap Clamp Part Numbers

Complete Set Assembled
CFC435M □□□ *KM

Complete Set Unassembled
CFC435M □□□ *K

****1=Pos.1; 2=Pos.2; 3=Pos.3
5=Pos.5; 6=Pos.6