

SINGLE-STAGE VACUUM GENERATORS 15 01 10, 15 01 10 LP, 15 01 15 LP and 15 03 10



Single-stage vacuum generator operation is based on the Venturi principle.

Supplying the generator with compressed air in P, vacuum will be generated at connection U, while both the supply and the sucked air will be released through R.

By interrupting the air supply in P, the vacuum effect in U will also stop. The optimal air supply pressure is normally 6 bar, but for generators with the letters LP in their item, a pressure lower than 4 bar is sufficient to obtain the best performance. Upon request, the vacuum generators can be supplied with a high sound suppression silencer installed on the R exhaust connection.

The single-stage vacuum generators are generally used to control vacuum cups, for gripping and handling non-porous objects and equipment with low flow rate requirements.

They are fully made with anodised aluminium, with brass or aluminium ejectors, depending on the items.



3D drawings are available on vuototecnica.net

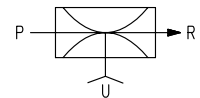
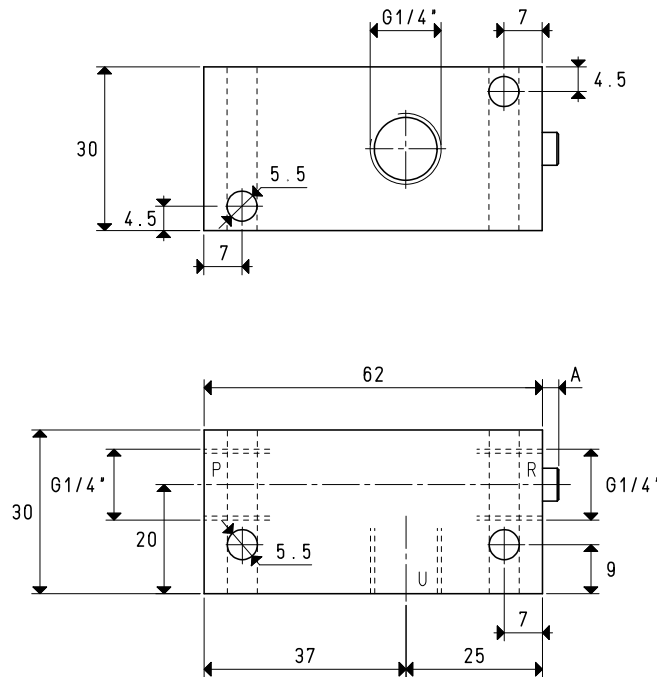

P=COMPRESSED AIR CONNECTION R=EXHAUST U=VACUUM CONNECTION

Item		15 01 10			15 01 10 LP			15 01 15 LP		
		Intake air flow rate	m ³ /h	2.7	2.8	2.9	2.6	2.8	3.0	4.8
Maximum level of vacuum	-kPa	55	70	85	43	61	85	40	61	85
Final pressure	mbar abs.	450	300	150	570	390	150	600	390	150
Supply pressure	bar	4	5	6	2	3	4	2	3	4
Optimal supply pressure	bar			6			4			4
Air consumption	NI/s	0.7	0.8	0.9	0.7	0.9	1.2	1.3	1.7	2.2
Operating temperature	°C			-20 / +100			-20 / +100			-20 / +100
Noise level at optimal supply pressure	dB(A)			63			62			71
Weight	g			140			130			130
A	mm						3			5

Note: All vacuum values indicated in the table are valid at the normal atmospheric pressure of 1013 mbar and obtained with a constant supply pressure.

Vacuum generator supply must be carried out with non-lubricated compressed air, 5 micron filtration, in accordance with standard ISO 8573-1 class 4.

Transformation ratio: N (newton) = Kg x 9.81 (force of gravity)

inch = $\frac{\text{mm}}{25.4}$; pounds = $\frac{\text{g}}{453.6} = \frac{\text{Kg}}{0.4536}$

Adapters for GAS - NPT threading available on page 1.130



SINGLE-STAGE VACUUM GENERATORS 15 01 10, 15 01 10 LP and 15 01 15 LP

Air flow rate (NI/s) at different level of vacuum (-KPa) at optimal supply pressure

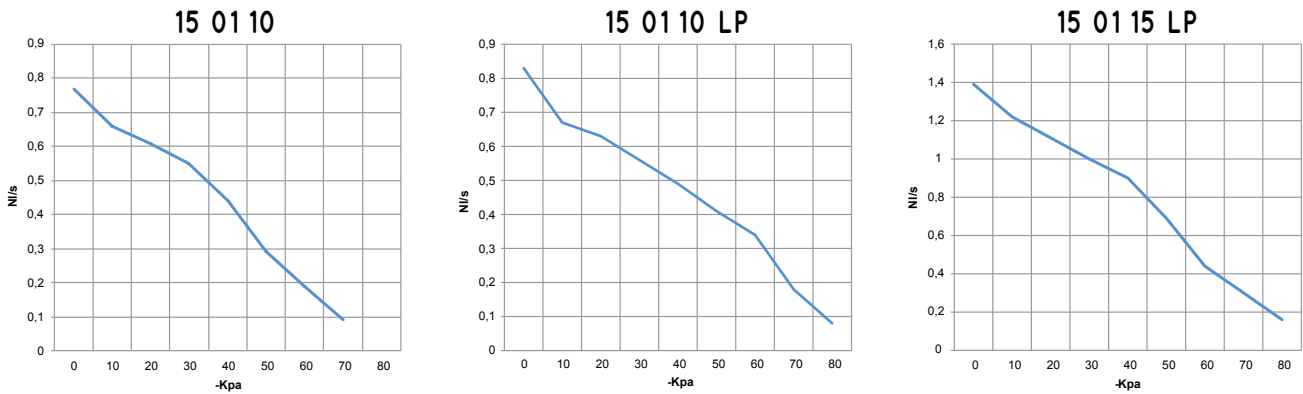

Generator item	Supp. press. bar	Air consumption NI/s	Air flow rate (NI/s) at different level of vacuum (-KPa) at optimal supply pressure										Max vacuum -KPa
			0	10	20	30	40	50	60	70	80		
15 01 10	6.0	0.9	0.80	0.66	0.61	0.55	0.44	0.29	0.19	0.09	--	85	
15 01 10 LP	4.0	1.2	0.83	0.67	0.63	0.56	0.49	0.41	0.34	0.18	0.08	85	
15 01 15 LP	4.0	2.2	1.39	1.22	1.11	1.00	0.90	0.69	0.44	0.30	0.16	85	

Evacuation rates (ms/l = s/m³) at different levels of vacuums (-KPa) at optimal supply pressure

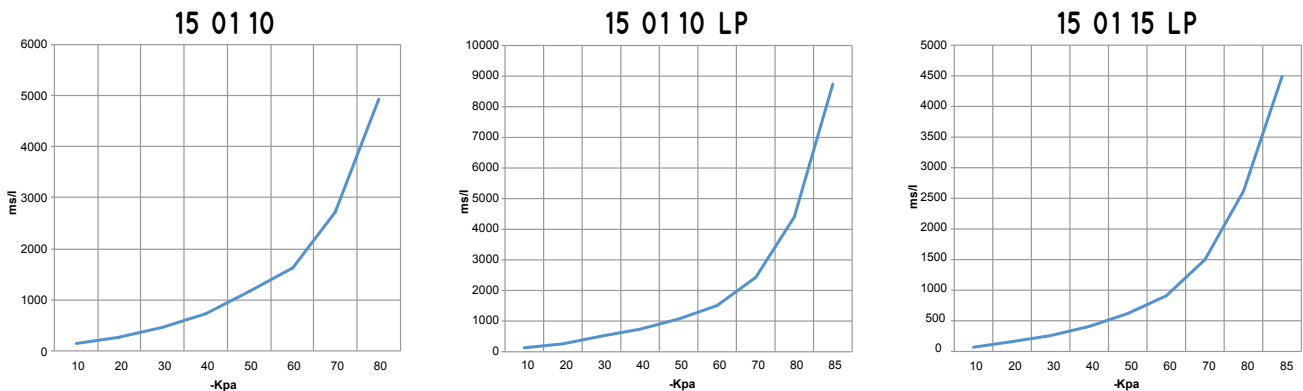

Generator item	Supp. press. bar	Air consumption NI/s	Evacuation rates (ms/l = s/m ³) at different levels of vacuums (-KPa) at optimal supply pressure									Max vacuum -KPa
			10	20	30	40	50	60	70	80	85	
15 01 10	6.0	0.9	139	278	472	727	1171	1628	2720	4928	--	85
15 01 10 LP	4.0	1.2	130	260	510	740	1070	1510	2430	4400	8740	85
15 01 15 LP	4.0	2.2	70	160	260	410	620	910	1500	2620	4490	85

ACCESSORIES UPON REQUEST

Silencer item SSX 1/4"

